

iT0420 Ice Cube Machine

Models

- IDT0420A IYT0420A IDT0420W IYT0420W



Indigo NXT Series iT420 Ice Machine on D320 Bin

Designed for operators who know that ice is critical to their business, the Indigo NXT Series ice machine's preventative diagnostics continually monitor itself for reliable ice production. Improvements in cleanability and programmability make your ice machine easy to own and less expensive to operate.

- **New levels of Performance** – Showcasing an average of 41% lower energy consumption, 21% reduction in in potable water usage and a 34% reduction in condenser water usage. This translates into lower cost of ownership over the life of your machine.
- **easyTouch[®] Display** - New icon based touch screen takes the guess work out of owning and operating an ice machine.
- **Programmable Ice Production** – Now its super easy to program your ice machine to be off at certain times of the day to save money with fluctuating electrical rates. Also programmable by daily ice production volume.
- **Easy to Clean Foodzone** – Hinge front door swing out for easy access. Removable water-trough, distribution tube, curtain, water probe and water pump for fast and efficient cleaning. Selected components are made with AlphaSan[®] antimicrobial.
- **Intelligent Diagnostics** – Provides 24 hour preventative maintenance and diagnostic feedback for trouble free operation.
- **Acoustical Ice Sensing Probe** – Unique patented technology allows for reliable operation in challenging water conditions and environments
- **DuraTech[®] Exterior** – Provides superior corrosion resistant above stainless steel. Innovative clear-coat resists fingerprints and dirt making it easier to keep clean.
- Available **LuminIce[®] II Growth Inhibitor** – Controls the growth of bacteria and yeast within the Food zone keeping the machine cleaner longer. A new indicator in the display keeps you abreast of the operational status.

Ice Machine Electric

115/60/1 standard
(208-230/60/1 also available)

Minimum circuit ampacity:

Air-cooled: 11.3, 115v, 5.5 208-230v
Water-cooled: 10.6, 115v, 5.2 -208-230v

Maximum fuse size:

Air-cooled: 15 1ph
Water-cooled: 15 1ph



Specifications

Operating Limits:

BTU Per Hour:
3,800 (average),
and 6,000 (peak)

Refrigerant:

R410A CFS - Free
Lowers global warming
by 48%

- Ambient Temperature Range:
40° to 110°F (4.4° to 43.3° C)
Water Temperature Range:
40° to 90°F (4.4° to 32.2° C)
- Water Pressure Ice Maker
Water In:
Min. 20 psi (137.9 kPa)
Max. 80 psi (551.1 kPa)

Ice Shape



Half Dice
3/8" x 1 1/8" x 7/8"
(.95 x 2.86 x 2.22 cm)



Dice
7/8" x 7/8" x 7/8"
(2.22 x 2.22 x 2.22 cm)





iT0420 on D-320 Storage Bin

- (A) Electrical Entrance (2) Options
- (B) 3/8" (0.95 cm) F.P.T. Water Condenser Inlet (water-cooled units)
- (C) 1/2" (1.27 cm) F.P.T. Water Condenser Outlet (water-cooled units)
- (D) 1/2" (1.27 cm) Auxillary Base Drain Socket
- (E) 3/8" (0.95 cm) F.P.T. Ice Making Water Inlet
- (F) 1/2" (1.27 cm) F.P.T. Ice Making Water Drain
- (G) 3/4" (1.91 cm) Bin Drain

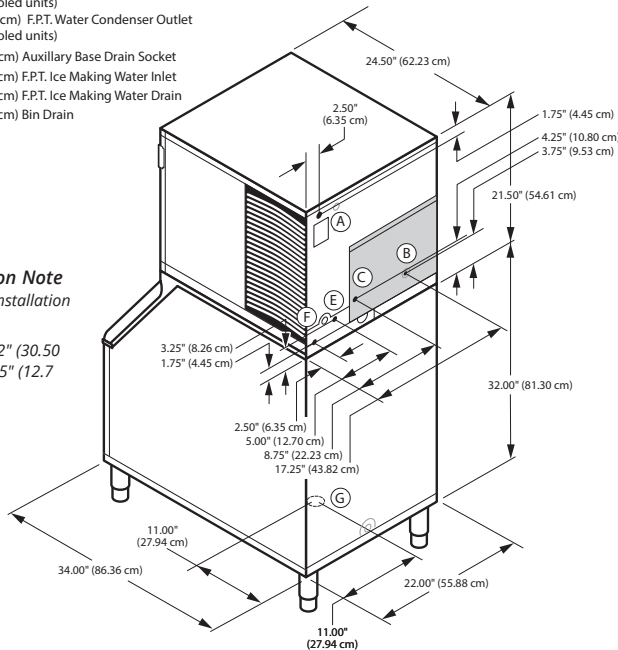

Installation Note
Minimum installation clearance:
Top/side: 12" (30.50 cm)
Back is 5" (12.7 cm)

Space-Saving Design



	iT0420 D-320	iT0420 D-420
Height	59.50" 151.13 cm	71.50" 181.61 cm
Width	22.00" 55.88 cm	22.00" 55.88 cm
Depth	34.00" 86.30 cm	34.00" 86.30 cm
Bin	264 lbs.	383 lbs.
Storage	118 kgs.	174 kgs.

Height includes adjustable bin legs 6.00" to 8.00", (15.24 to 20.32 cm) set at 6.00" (15.24 cm).
Bin capacity is based on 90% of the volume x 33 lbs/ft³ average density of ice.

Specifications

	Model	Ice Shape	Ice Production 24 Hours		Power Usage kWh/100 lbs. @90°Air/70°F	Potable Water Usage/100 lbs. 45.4 kgs. of Ice
			70°Air/ 50°F Water	90°Air/ 70°F Water		
AIR COOLED	IDT0420A	dice	470 lbs.	375 lbs.	5.6 ★	19 Gal.
			213 kgs	170 kgs		
AIR COOLED	IYT0420A	half-dice	460 lbs.	375 lbs.	5.4 ★	19 Gal.
			209 kgs	170 kgs		
WATER COOLED	IDT0420W	dice	454 lbs.	400 lbs.	4.28	19 Gal.
			206 kgs	181 kgs		
WATER COOLED	IYT0420W	half-dice	490 lbs.	425 lbs.	4.24	19 Gal.
			222 kgs.	193 kgs		

* Water-cooled Condenser Water Usage / 100 lbs. /45.4 kgs. Of Ice: 140 gal/ 530 L.
*Water-cooled models are excluded from ENERGY STAR qualification.

Order separately: Ice storage bin for all units
★ENERGY STAR® 3.0

Accessories

LuminIce® II Growth Inhibitor
reduces yeast and bacteria growth for a cleaner ice machine.



External Scoop holder
Protect the ice scoop with the NSF approved versatile scoop holder.

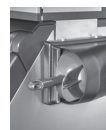

Arctic Pure® Water Filters
Reduces sediment and chlorine odors for better tasting ice.



iAuCS®
schedules and performs routine ice machine cleaning automatically.



Welbilt reserves the right to make changes to the design or specifications without prior notice.



SPA-160 • SFA-191 Ice Dispensers

SPA-160 • SFA-191 Ice Dispensers

Model

- SPA-160 SFA-191

ONLY 22" WIDE

SPA Model

Designed for ice bucket filling in hotels, motels, and resorts

With Indigo and Indigo NXT ice machines you can program the ice machines to be off certain hours of the day so that while the hotel guests are sleeping, the ice machine can be too!



Indigo NXT iT0620 Ice Machine
SPA-160 Ice Dispenser

SFA Model

Designed for "large" container ice filling. Accepts up to 10.5" (26.67 cm) high container

Built-in water valve



Indigo NXT iT0620 Ice Machine
SFA-191 Ice & Water Dispenser



Standard Features

- 120 lbs. (54.4 kgs.) ice storage capacity. Accepts 22" (55.88 cm) wide Manitowoc ice machine.
- Only 22" (55.88 cm) wide, 31" (78.7 cm) deep, and 75.5" high (191.77 cm).
- Patented rocking chute dispense mechanism reduces in-flight ice and ice spillage with quick on/off activation.
- Efficient built-in agitator assures 100% dispensing. Oversized drain pan collects larger quantity of ice overflow.
- DuraTech™ exterior provides superior corrosion resistance. Stainless finish with innovative clear-coat resists fingerprints and dirt.

Warranty

- 5-year parts and 5-year labor coverage on ice machine evaporator.
- 5-year parts and 3-year labor coverage on ice machine compressor.
- 3-year parts-and-labor coverage on all other ice machine and dispenser components.

Ice Shape



Half Dice
3/8" x 1 1/8" x 7/8"
(.95 x 2.86 x 2.22 cm)



Dice
7/8" x 7/8" x 7/8"
(2.22 x 2.22 x 2.22 cm)



COMPANY WITH
QUALITY SYSTEM
CERTIFIED BY DNV
= ISO 9001:2008 =

Welbilt reserves the right to make changes to the design or specifications without prior notice.

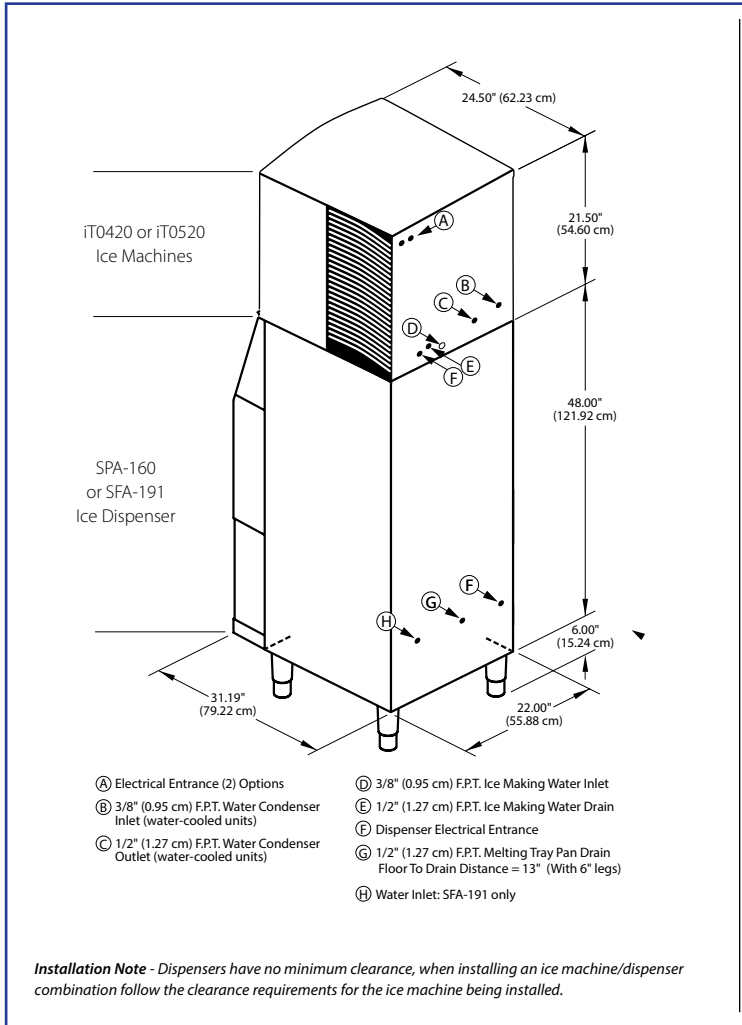

Ice Machine Electric

Note: Dispenser will accept single 22" wide ice machine. Ice machine ordered separately. Choose Dice or Half Dice cube size. Refer to ice machine specification sheet for electrical and complete AHRI standard ratings.

Dispenser Electric:

115/60/1. (208-230/60/1 and 230/50/1 also available.)

Maximum Circuit Fuse Size:

15.0 amps. HACR-type circuit breakers can be used in place of fuses.

Dispenser Electrical Connection:

6' power cord, rated 125 VAC, 16-3 conductors with standard 3-prong, straight-blade, ground-type plug (NEMA configuration 5-15P).

Motor:

1.6 amps maximum. Permanently lubricated.

Service Access:

Dispenser door removes easily to access components.

Model Options:

SPA-160 push-for-ice rocking chute, SFA-191 has a water valve option.

Series iT0420 (115 volt)

Model	Ice Shape	Ice Production 24 Hours			
		70°Air/50°F Water		90°Air/70°F Water	
		lbs.	kgs.	lbs.	kgs.
IDT-0420A	dice	470	213	375	170
IDT-0420W	dice	454	206	400	181
IYT-0420A	half-dice	460	209	375	170
IYT-0420W	half-dice	490	222	425	193

Series iT0620 (115 volt)

Model	Ice Shape	Ice Production 24 Hours			
		70°Air/50°F Water		90°Air/70°F Water	
		lbs.	kgs.	lbs.	kgs.
IDT-0620A	dice	525	238	410	186
IDT-0620W	dice	560	254	450	204
IYT-0620A	half-dice	530	240	450	204
IYT-0620W	half-dice	575	261	465	211

LuminIce® II Growth Inhibitor reduces yeast and bacteria growth for a cleaner ice machine.



ArcticPure® Water Filters

AR-Pre filters, dirt, rust and sediment.



AR-10000 reduces: scale, chlorine taste, and odor. Ice looks and tastes better.

