



**John
BOOS**
Since 1887

ITEM #: _____ QTY: _____
 MODEL #: _____
 PROJECT NAME: _____

062217

3601 S. Banker St. Effingham, IL 62401 • P.O. BOX 609 • Ph: (888) 431-2667 • Fax: (800) 433-2667

"EUBIB-18CP" SLIM-LINE UNDERBAR INSULATED ICE BINS W/ COLD PLATE

FEATURES:

- STAINLESS STEEL CIRCUITS IN SOLID ALUMINUM PLATE
- AVAILABLE IN 7-CIRCUIT COLD PLATE
- AVAILABLE IN 10-CIRCUIT COLD PLATE
- INSULATED ICE BIN 12" DEEP WITH DRAIN
- STAINLESS STEEL LEGS AND BRACING WITH ADJUSTABLE BULLET FEET
- ICE BIN LID INCLUDED

MATERIAL:

- TOP: 18GA 300 SERIES STAINLESS STEEL
- BRACING: STAINLESS STEEL
- LEGS: STAINLESS STEEL
- GUSSETS: STAINLESS STEEL
- FEET: PLASTIC

CONSTRUCTION:

- TOP: STAINLESS STEEL TOPS ARE TIG WELDED, EXPOSED WELDS ARE POLISHED TO MATCH ADJACENT SURFACE.

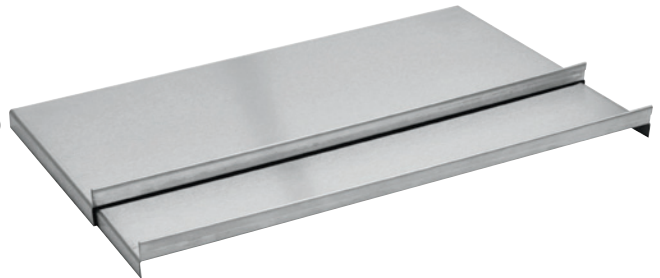

SLIM-LINE 7-CIRCUIT COLD PLATE UNDERBAR INSULATED ICE BINS



MODEL #	QTY
EUBIB-2418CP7	
EUBIB-3018CP7	
EUBIB-3618CP7	
EUBIB-4818CP7	

SLIM-LINE 10-CIRCUIT COLD PLATE UNDERBAR INSULATED ICE BINS



MODEL #	QTY
EUBIB-3018CP10	
EUBIB-3618CP10	
EUBIB-4818CP10	



EUBIB-2418CP7

OPTIONAL ACCESSORIES

MODEL #	QTY
SPEED RAILS	
STAINLESS STEEL LEGS	



DETAILED SPECIFICATIONS

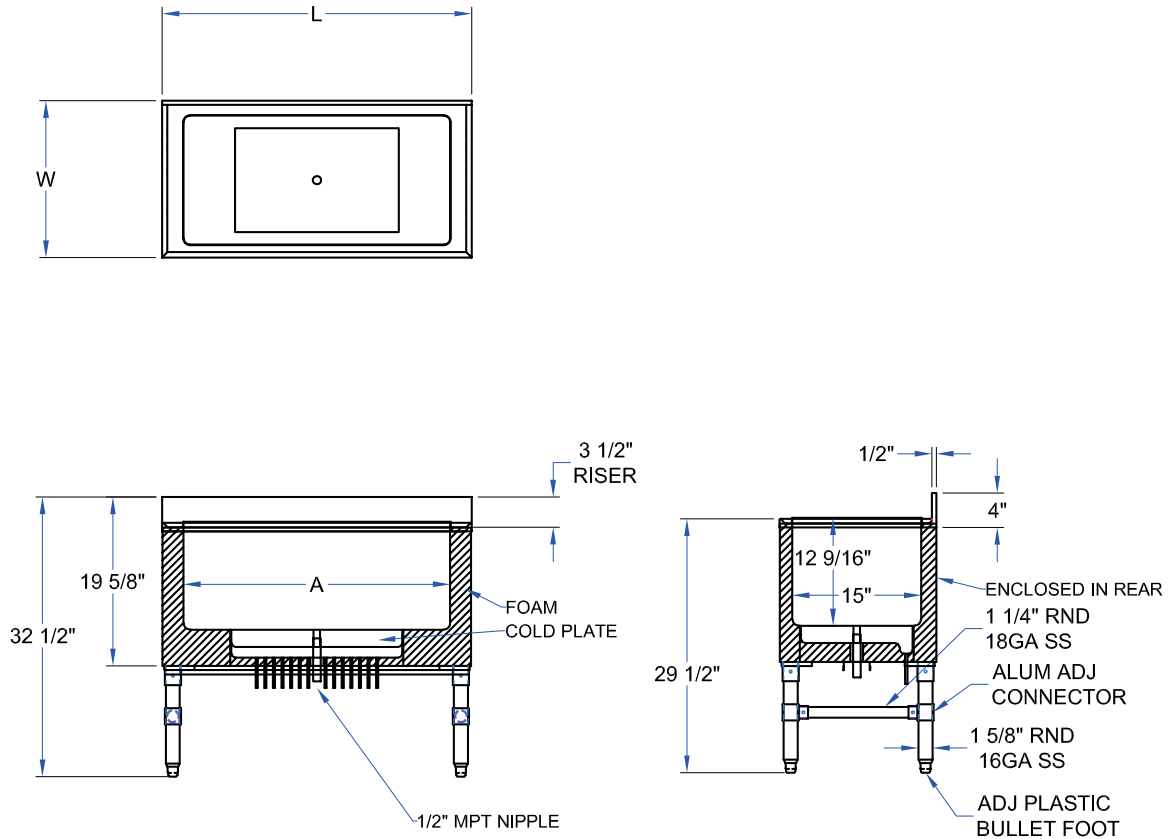

SLIM-LINE 7-CIRCUIT COLD PLATE UNDERBAR INSULATED ICE BINS

MODEL #	LENGTH	WIDTH	HEIGHT	A	WT. (LBS)
EUBIB-2418CP7	24"	18"	29-1/2"	20-3/8"	65
EUBIB-3018CP7	30"	18"	29-1/2"	25"	83
EUBIB-3618CP7	36"	18"	29-1/2"	31"	92
EUBIB-4818CP7	48"	18"	29-1/2"	43"	137

WEIGHTS ARE SUBJECT TO ADDITIONAL PACKAGING



SLIM-LINE 10-CIRCUIT COLD PLATE UNDERBAR INSULATED ICE BINS

MODEL #	LENGTH	WIDTH	HEIGHT	A	WT. (LBS)
EUBIB-3018CP10	30"	18"	29-1/2"	25"	85
EUBIB-3618CP10	36"	18"	29-1/2"	31"	94
EUBIB-4818CP10	48"	18"	29-1/2"	43"	143

WEIGHTS ARE SUBJECT TO ADDITIONAL PACKAGING

SOME UNITS SHIP UNASSEMBLED FOR REDUCED SHIPPING COST. ALL DIMENSIONS ARE TYPICAL. TOLERANCE +/- .500"
John Boos & Co. is constantly engaged in a program of improving products and therefore reserves the right to change specifications without prior notice.

