

ITEM #: \_\_\_\_\_ QTY: \_\_\_\_\_  
 MODEL #: \_\_\_\_\_  
 PROJECT NAME: \_\_\_\_\_

3601 S. Banker St. Effingham, IL 62401 • P.O. BOX 609 • Ph: (888) 431-2667 • Fax: (800) 433-2667

## UNDERBAR LIQUOR DISPLAY

**FEATURES:**

- 4-STEP LIQUOR DISPLAY
- GALVANIZED LEGS AND BRACINGS
- ADJUSTABLE BULLET FEET

**CONSTRUCTION:**

- TOP: STAINLESS STEEL TOPS ARE TIG WELDED, EXPOSED WELDS ARE POLISHED TO MATCH ADJACENT SURFACE.

**MATERIAL:**

- TOP: 18GA 300 SERIES STAINLESS STEEL
- BRACING: GALVANIZED
- LEGS: GALVANIZED
- GUSSETS: GALVANIZED
- FEET: PLASTIC



EUBLD-1821

**UNDERBAR LIQUOR DISPLAY**

MODEL #	QTY
EUBLD-1221	
EUBLD-1821	
EUBLD-2421	

# LIQUOR DISPLAY DETAILED SPECIFICATIONS

## PLAN VIEW

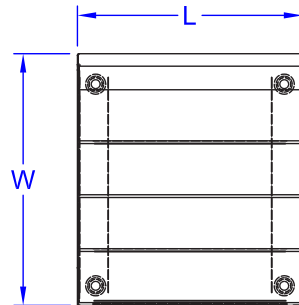

## FRONT ELEVATION

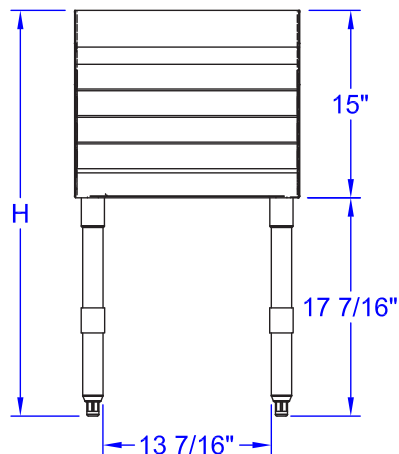

## SIDE VIEW

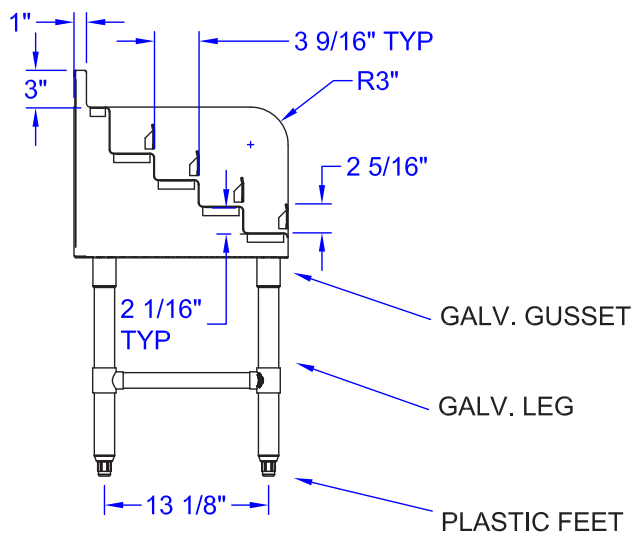

### UNDERBAR LIQUOR DISPLAY

MODEL #	LENGTH	WIDTH	HEIGHT	WT. (LBS)
EUBLD-1221	12"	21"	32-1/2"	32
EUBLD-1821	18"	21"	32-1/2"	37
EUBLD-2421	24"	21"	32-1/2"	40

WEIGHTS ARE SUBJECT TO ADDITIONAL PACKAGING

SOME UNITS SHIP UNASSEMBLED FOR REDUCED SHIPPING COST. ALL DIMENSIONS ARE TYPICAL. TOLERANCE +/- .500"  
John Boos & Co. is constantly engaged in a program of improving products and therefore reserves the right to change specifications without prior notice.