



Over 90 Years Of Quality Foodservice
Products And Service

Job _____ Item No. _____

11 Quart Round Heavy Duty Thermostatically Controlled Counter Top Warmer

MODEL SW-10T



Model SW-10T

DESCRIPTION

Wells SW-10T heavy-duty, thermostatically controlled, counter top warmers are designed to hold heated foods at safe and fresh serving temperature and will accommodate one 11 Quart round inset pan or one 7 Quart or 4 Quart round inset pan when used with the appropriate adaptor top.

SPECIFICATIONS

Construction – Exterior is all heavy gauge stainless steel for easy maintenance and durable performance while the all stainless steel warming pan is deep-drawn for maximum strength and ease of cleaning. A set of four 1” legs are standard.

Insulation – the SW-10T is fully insulated around the side and bottom for energy savings, quicker pre-heat and faster recovery.

Controls & Heating – SW-10T features positive-off thermostatic controls for precise and consistent temperature control and includes a temperature-ready indicator light. Tubular elements are located under the warming pan for quick heating. Protective ring guard prevents accidental temperature changes while protecting the control knob from collisions.

STANDARD FEATURES

- 120v , 1Ø, 825 watts
- Positive on / off thermostatic controls
- Signal light indicating heating element is energized
- NEMA 5-15P cord & plug
- Stainless steel exterior
- stainless steel, deep drawn warming pan
- Accommodates 11 quart round inset pan
- Accommodates 7 quart or 4 quart round inset pans with optional adaptor tops
- Energy saving insulation
- Powerful tubular elements located under warming pan
- Wet or dry operation (wet recommended)
- Set of four 1” legs
- Limited 3-year parts & 1-Year labor warranty

OPTIONS & ACCESSORIES

- Adaptor top to convert to 7 quart inset pan # 20175
- Adaptor top to convert to 4 quart inset pan # 20822
- Round Inset 11 quart with handles and slotted lid # 20908
- Round Inset 11 quart with hinged lid, no handles #21057
- Round Inset 7 quart with lid # 20587
- Round inset 4 quart with lid # 20774
- Leg Kit set of 4 each 4” legs # 20314

CERTIFICATIONS



LISTED STD.4
E6070

Sheet No. WELLS-SW10T-03/15



Wells Bloomfield • 10 Sunnen Dr. St. Louis, MO 63143 U.S.A.

Phone : (314) 678-6314 • Fax (314) 781-3636

www.wellsbloomfield.com • Printed in the U.S.A.

NOTE: Specifications are subject to change without notice and are not intended for installation purposes. See installation instructions prior to installing the unit.



Over 90 Years Of Quality Foodservice
Products And Service

11 Quart Round Heavy-Duty Thermostatically Controlled Counter Top Warmer

MODEL □ SW-10T

GENERAL LAYOUT DATA
FOOD AND LIQUID WARMER
MODEL SW-10T

INCHES
(MM)



NOTE: Specifications are subject to change without notice.

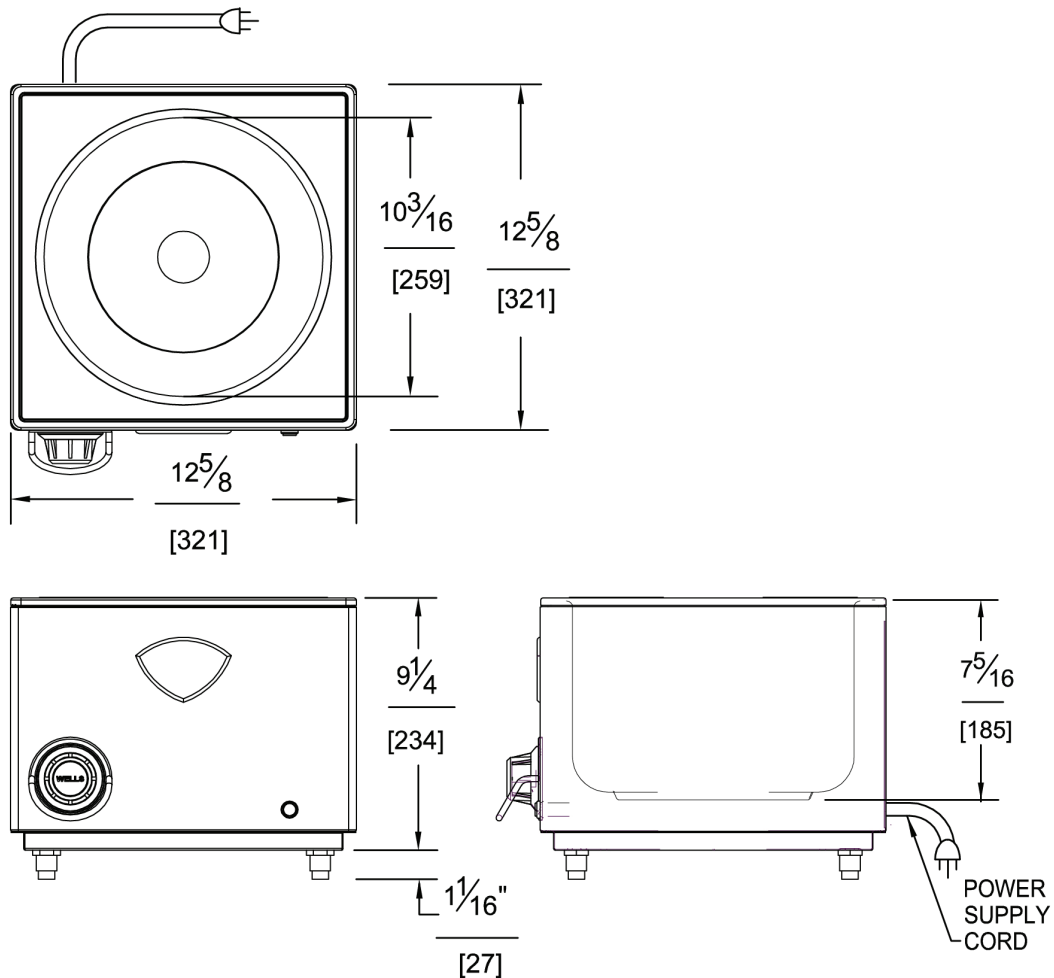

TYPICAL SPECIFICATIONS

MODEL	VOLTS	WATTS	AMPS	PHASE	POWER SUPPLY CORD	SHIP WEIGHT
SW-10T	120	825	6.9	SINGLE	NEMA 5-15P	14 lbs. (6.4 kilos) 1.62 cubic feet

Due to periodic changes in designs, methods, procedures, policies and regulations, the specifications contained in this sheet are subject to change without notice. While Wells exercises good faith efforts to provide information that is accurate, we are not responsible for errors or omissions in information provided or conclusions reached as a result of using the specifications. By using the information provided, the user assumes all risks in connection with such use.



Wells Bloomfield • 10 Sunnen Dr. St. Louis, MO 63143 U.S.A.
 Phone: (314) 678-6314 • Fax (314) 781-3636
 www.wellsbloomfield.com • Printed in the U.S.A.

NOTE: Specifications are subject to change without notice and are not intended for installation purposes. See installation instructions prior to installing the unit.