



Designer Series Electric Fryer

Item: _____
 Quantity: _____
 Project: _____
 Approval: _____
 Date: _____

Designer Series Electric Fryer

Models:

- ED-15F EDU-18F ED-30FT
 ED-15SF EDU-18SF ED-30SFT

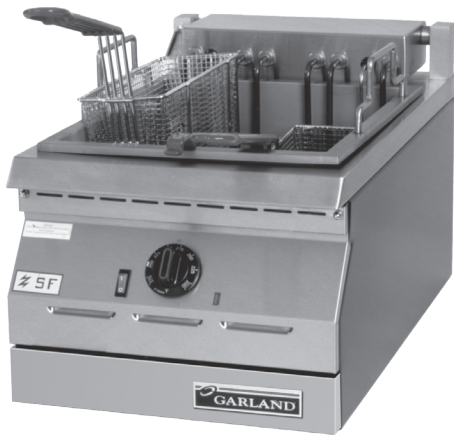

Model ED-15SF

Standard Features:

- Stainless steel front and sides
- Removable stainless steel tank, 17Lb (7.7Kg) capacity
- Set of twin fryer baskets
- Easy clean design with recessed protected controls.
- Heat-On indicator lamps
- 5300 watts per frypot
- Super fryer with 8000 watts per frypot, has suffix SF or SFT
- Models with EDU prefix are "CE" approved
- One-Year limited parts & labor warranty (USA & Canada only)

Optional Features:

- Stainless steel back and bottom
- Stainless steel bowl cover, one required per frypot
- Stainless steel fryer fish plate
- One large fryer basket in lieu of twin set of baskets

Note: Stands are available see form # CS24/CSD

Specifications:

Electric designer series fryers in two size groups: Single tank models; 15" (381mm) wide ED-15F/SF, or 18" (457mm) wide EDU-18F/SF (CE approved); and twin tank models 30" (782mm) wide ED-30FT/SFT. Designed as free standing or to be banked with other ED series equipment. 24" (610mm) deep x 13" (330mm) high with stainless steel front and sides, and stainless steel tank. Electronic thermostat provides concise accurate control. Removable flat bottom stainless steel tank with large surge. Twin tank model has two sets of independent controls. 5300 watts per frypot, super fryer available with 8000 watts per frypot; models with suffix SF or SFT. Models with prefix EDU are "CE" approved.



Models	Total kW Load				Nominal Amperes Per Line							
					North America				Export			
	North America		Export		Single Phase		Hi Line -3 Phase		Single Phase		Hi Line - 2 or -3 Phase	
208V	240V	220V/380V	240V/415V	208V	240V	208V	240V	220V/380V	240V/415V	220V/380V	240V/415V	
ED-15F, EDU-18F	5.3	5.3	5.93	5.3	26	23	N/A	N/A	27	23	N/A	N/A
ED-15SF, EDU-18SF	8	8	8	8	39	34	23	20	37	34	13	12
ED-30FT	10.6	10.6	11.86	10.3	51	45	45	39	54	45	27	22
ED-30SFT	16.0	16.0	16.0	16.0	77	67	45	39	73	67	25	23

Model	Overall Dimensions			Cu. Ft.	Shipping Wt. Lb/kg
	Height	Width	Depth		
ED-15F, ED-15SF	13" (330mm)	15" (381mm)	24" (610mm)	5	50/23
EDU-18F, EDU-18SF	13" (330mm)	18" (457mm)	24" (610mm)	5	50/23
ED-30FT, ED-30SFT	13" (330mm)	30" (762mm)	24" (610mm)	10	70/32

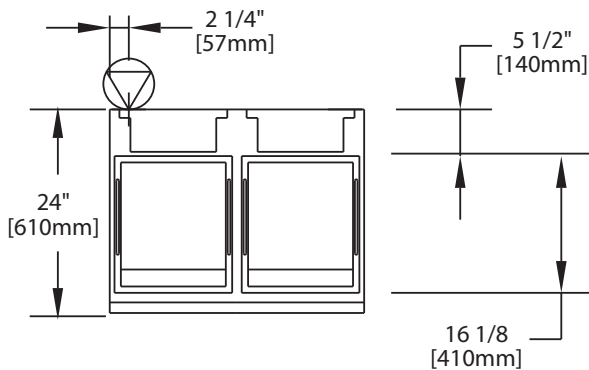

Garland products are not approved or authorized for home or residential use, but are intended for commercial applications only. Garland will not provide service, warranty, maintenance or support of any kind other than in commercial applications.

Installation Clearances	
Side	Rear
0.5" (13mm)	0.5" (13mm)

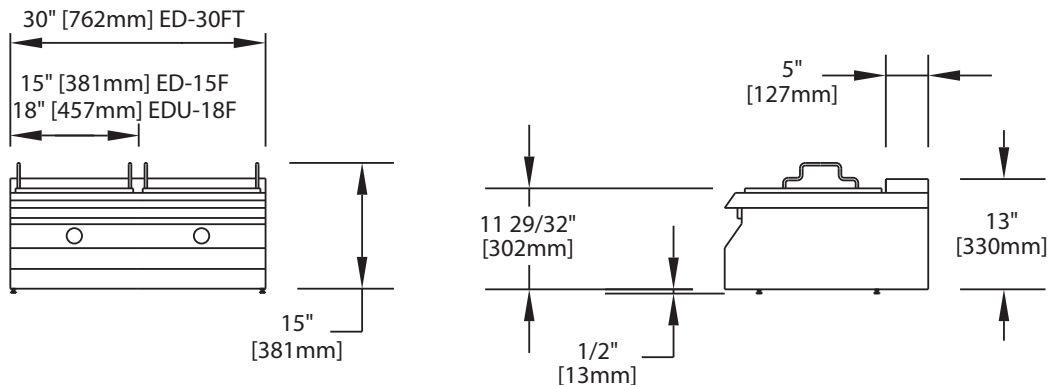

Form# ED-15F (10/20/11)