



RESTAURANT SERIES RANGES

SERIES: BP-24"



Bakers Pride® 24" range feature a 30,000 BTUH oven and the choice three different stovetop configurations: a four-burner range, a single griddle, or two burners with one 12" griddle. Cleaning is easy thanks to the lift-off burner heads and removeable oven door. The cast-iron section grates are designed to allow pots to slide from section to section and are engineered with an anti-clogging shield for long-lasting performance. In the oven, a unique burner baffle distributes heat evenly throughout the oven, which is also porcelainized on five contact surfaces. Available for use with natural gas or liquid propane.

VANTAGE STOVETOP CONFIGURATION

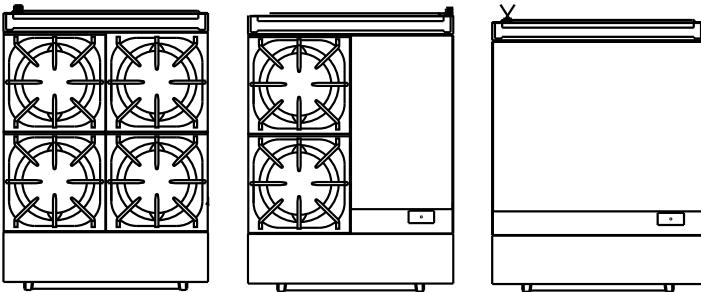

FEATURES AT A GLANCE

- 40,000 BTUH burners
- Lift-off burner heads
- Natural or LP gas
- One 20" (508 mm) wide, 30,000 BTUH oven
- Rack guides have four positions for two standard wire racks (Ribbed bottom is fifth position.)
- 7" (178 mm) landing ledge
- 6" (152 mm) adjustable legs
- Oven is porcelainized on bottom, sides, back, and door liner
- 12" (305 mm) sq. cast-iron section grates
- Removable oven door
- Unique burner baffle design
- Stainless steel front, sides, landing ledge, back guard, and shelf
- Aluminized sides
- 1" (25 mm) thick griddle (on specific models)
- Burner for every 12" (305 mm) of griddle surface
- Anti-clogging grate shields
- One-year limited warranty

OPTIONS & ACCESSORIES

- Raised griddle
- Additional oven racks
- Casters (set of four)
- Gas conversion kits
- Thermostatic griddle
- Stub back





RESTAURANT SERIES RANGES

SERIES: BP-24"

EQUIPMENT DIMENSIONS

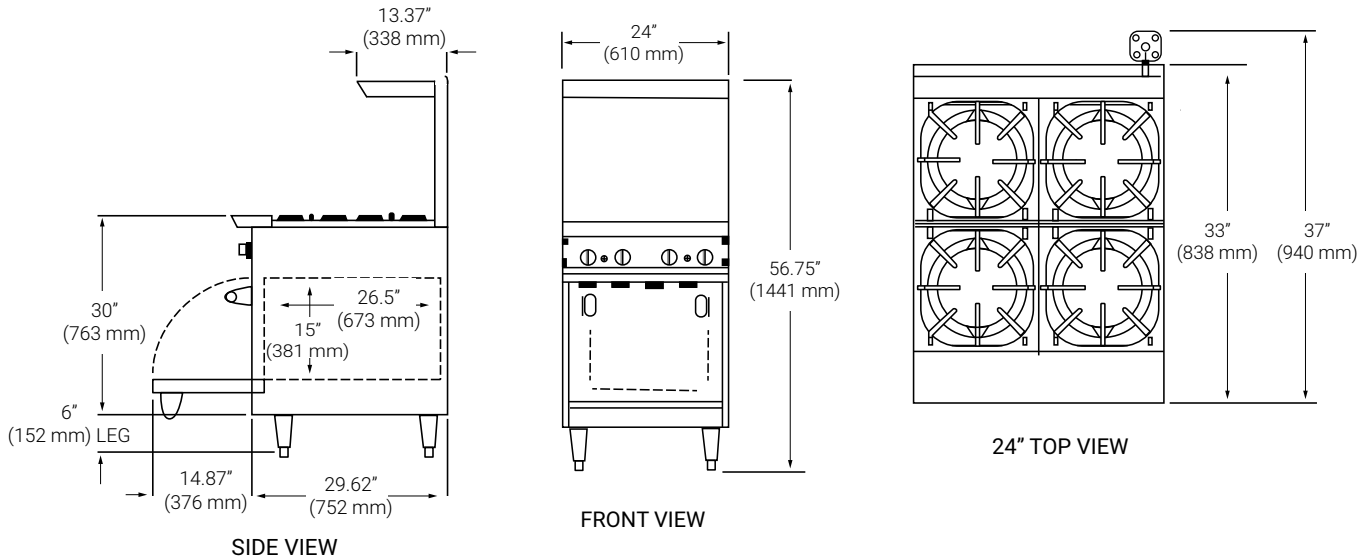

MECHANICAL SPECIFICATIONS

Model #	BTU	# 12" sq. Grates	Griddle Width	Oven Width	Overall Dim (W x H x D)*	Carton Dim (W x H x D)	Cubic Feet	Cubic Meter	Ship Wt.
24-BP-4B-S20	190,000	4	n/a	20" (508)	24" x 56.75" x 37" (610 x 1441 x 940)				480 (218kg)
24-BP-2B-G12-S20	130,000	2	12" (305)	20" (508)	24" x 56.75" x 37" (610 x 1441 x 940)				480 (218kg)
24-BP-0B-G24-S20	70,000	n/a	24" (610)	20" (508)	24" x 56.75" x 37" (610 x 1441 x 940)				480 (218kg)

*Height includes 6" legs. Depth includes 4" gas regulator.

OVEN INTERIOR DIMENSIONS

20.5" x 15" x 26.5"
(521 x 381 x 673)

REQUIRED CLEARANCES

	Combustible
Left	10" (254 mm)
Right	10" (254 mm)
Back	4" (102 mm)

GAS CONNECTIONS

Manifold pressure is 5.0" W.C. or natural gas or 10.0" for propane gas. Manifold size is 3/4" NPT.
3/4" pressure regulator supplied with equipment to be installed at time of connection.
Must specify type of gas and elevation if over 2000 ft. when ordering.



Freight Class: 110
FOB: Allen, 75013

Bakers Pride reserves the right to modify specifications or discontinue models without incurring obligation. Dimensions nominal.

