



3' MULTI-SHELF MERCHANDISER – SELF-SERVE – MULTIPLE SHELF CONFIGURATIONS – AIR CURTAIN

# Model HSS3



Ideal for supermarkets and high-volume food service operations, the BKI® HSS series of merchandisers will precisely maintain various products at their optimum holding temperatures with an ambient air curtain.

The HSS3 is a 3' wide merchandiser with your choice of 2-5 slanted shelf configurations. The front is open for quick grab-n-go service and has an optional sliding rear door for loading.

Each shelf is individually heated, which allows you the to set the optimum temperature for each shelf depending on the product. Every shelf has an integrated pricing tag rail and is illuminated with a shatter-resistant florescent bulb.

The HSS series of merchandisers is also offered in 2' and 4' widths. So no matter the volume or floor space available, we are sure to have a merchandiser to fit your needs.

## FEATURES AT A GLANCE

- Heated shelves with independent temperature control
- Ambient barrier with heated air curtain maintains temperature & freshness
- Built-in spill edge
- Pricing tag rails
- Optional sliding rear door
- Durable tempered glass end panels
- 100% hand built in the U.S.A.



### PRODUCT CAPACITY

Hold up to 40 chicken domes for display depending on shelf configuration.



### ELECTRIC OPERATION

Energy efficiency and easy installation are a perfect pairing for your food service operation.

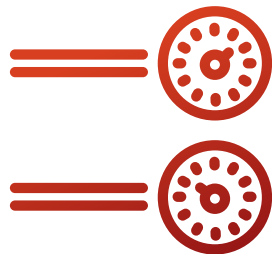

### INDIVIDUAL TEMP. CONTROL

Control the temperature of individual shelves depending on product.



### AIR CURTAIN

An ambient air curtain helps keep food temps as low as 60°F (15°C).



3' MULTI-SHELF MERCHANDISER – SELF-SERVE – MULTIPLE SHELF CONFIGURATIONS – AIR CURTAIN

# Model HSS3

## EQUIPMENT DIMENSIONS

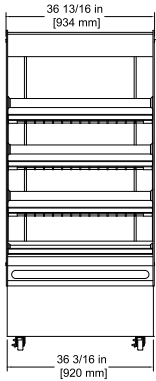

HSS3 4-SHELVES

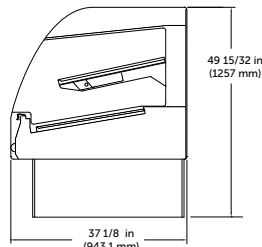

SHELF CONFIG. (2)

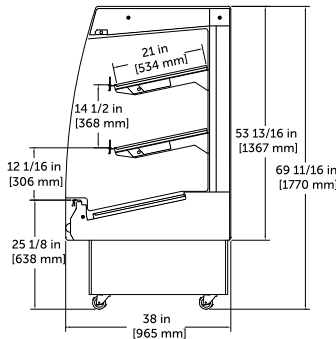

SHELF CONFIG. (3)

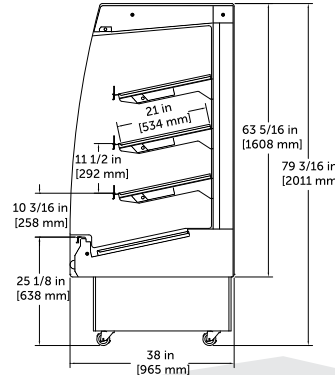

SHELF CONFIG. (4T)

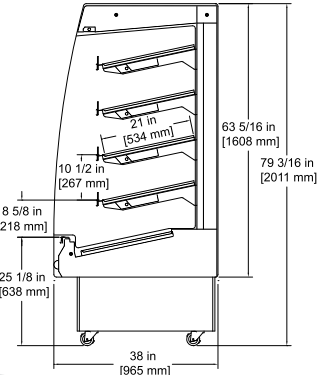

SHELF CONFIG. (5)

## MECHANICAL SPECIFICATIONS

Dimension	HSS3
Height/Shelf Config.	
2	49 15/32" (1257 mm)
3 & 4S	69 11/16" (1770 mm)
4T & 5	79 3/16" (2011 mm)
Width	36 13/16" (934 mm)
Depth	38" (965 mm)
Weight/Shelf Config.	
2	524 lb (238 kg)
3 & 4S	607 lb (275 kg)
4T & 5	640 lb (290 kg)

## ELECTRICAL SPECIFICATIONS:

Shelf Config.	Volts	Phase	Cycles	Wires	kW	Amps
2	208	1	50/60 Hz	2 + G	3452	16.6
	220	1	50/60 Hz	2 + G	3678	16.7
	230	1	50/60 Hz	2 + G	4020	17.5
	240	1	50/60 Hz	2 + G	4377	18.2
3	208	1	50/60 Hz	2 + G	3902	18.8
	220	1	50/60 Hz	2 + G	4090	18.6
	230	1	50/60 Hz	2 + G	4470	19.4
	240	1	50/60 Hz	2 + G	4867	20.3
4S & 4T	208	1	50/60 Hz	2 + G	4352	20.9
	220	1	50/60 Hz	2 + G	4502	20.5
	230	1	50/60 Hz	2 + G	4920	21.4
	240	1	50/60 Hz	2 + G	5357	22.3
5	208	1	50/60 Hz	2 + G	4802	23.1
	220	1	50/60 Hz	2 + G	4913	22.3
	230	1	50/60 Hz	2 + G	5370	23.3
	240	1	50/60 Hz	2 + G	5847	24.4

## OPTIONS

- Back sliding doors

## SHELF SIZE AND CAPACITY:

Model	Width	Depth	Area	Capacity
HSS3	35" (889 mm)	21 1/2" (546 mm)	5.22 sq ft (33.7 sq cm)	8 Standard chicken domes per shelf



Visit [bkideas.com](http://bkideas.com) to view all accessories available for this model.

5.20.2016

bkideas.com

© BKI LI0283C/08-06

Specifications are subject to change without notice.

BKI North America  
 PO Box 80400  
 Simpsonville, SC 29680-0400 USA  
 Telephone: (864) 963-3471  
 Toll Free: (800) 927-6887

