



LARGE VOLUME DEEP FRYER – PRESSURE – MANUAL CONTROLS – FILTER SYSTEM

Model LGF-F



This large gas-operated pressure fryer can take natural or LP gas and is designed for simple operation, long life, and high volume. The manual controls are easy to use and the lower initial cost will get you cooking fast. The BKI® LGF-F fryer cooks up to 14 lb (6.4 kg) of product in one cycle and holds 35 lb (15.9 kg) of oil.

The results from pressure frying are delicious! As pressure builds up in the vat, moisture in the protein is trapped, leaving you with perfectly tender and moist meat while retaining a crispy exterior. Food coming out of the pressure fryer has a longer holding "life" too, which is perfect for grocery deli grab-n-go displays. Combine this fryer with a hot case and your food will be hot and crispy for hours!

The automatic filtration system keeps oil fresh and extends its usable life. This saves you money over the life of the fryer and keeps your food tasting consistent every time. A built-in cold zone in the vat collects breading fall-off, keeping oil fresh and clean. With the push of a button and the twist of a handle, filtering oil is easy and safe. The patented quick-disconnect allows for easy removal of the filtering vat.

FEATURES AT A GLANCE

- 14 lb (6.4 kg) product, 35 lb (15.9 kg) oil capacity
- Utilizes controlled low pressure
- Pressure-regulated lid interlock system
- 3" casters for easy mobility
- Gas operation
- Stainless steel construction
- Manual controls
- Digital timer
- Automatic, quick-disconnect filter system
- Assembled in USA



PRESSURE COOKING

Pressure cooking results in moist and tender meat and longer holding life.



GAS OPERATION

Natural or LP gas is powerful and efficient with incredible recuperation times.

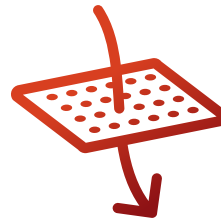

AUTOMATIC FILTRATION

Automatic filtration ensures consistent-tasting food and longer oil life.



LARGE VOLUME DEEP FRYER – PRESSURE – MANUAL CONTROLS – FILTER SYSTEM

Model LGF-F

EQUIPMENT DIMENSIONS

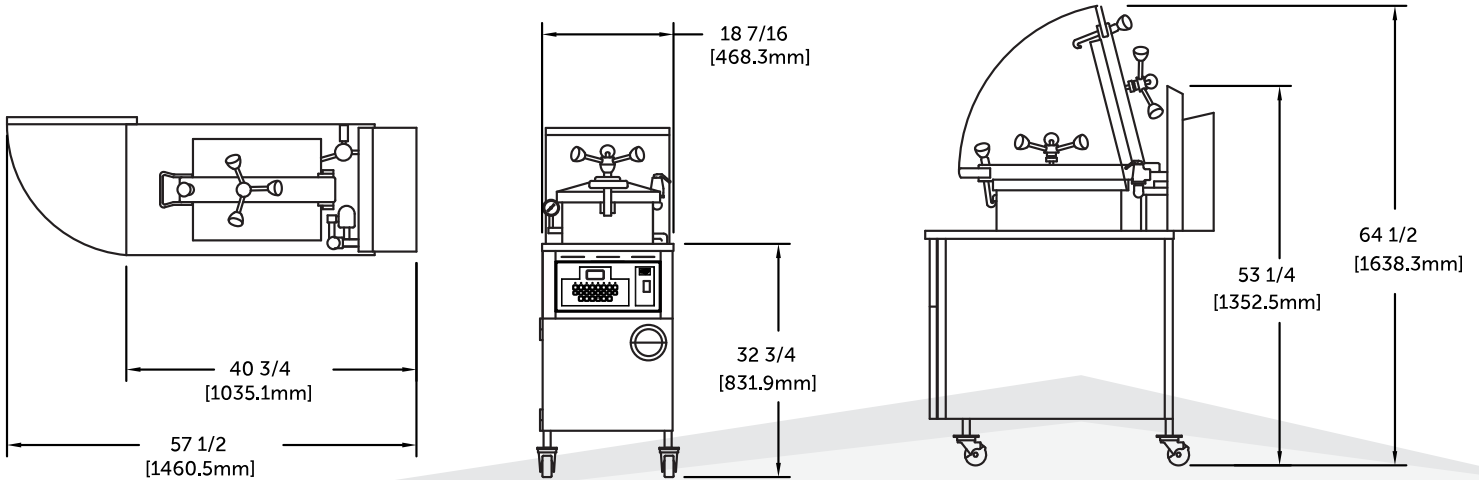

MECHANICAL SPECIFICATIONS

Dimension	Uncrated	Crated
Height	53.25" (1353 mm)	57" (1450 mm)
Width	18.43" (468 mm)	27" (687 mm)
Depth	40.75" (1035 mm)	42" (1069 mm)
Floor Space	5.2 sq ft (.48 sq m)	7.9 sq ft (.73 sq m)
Weight	440 lb (199.6 kg)	460 lb (208.7 kg)

ELECTRICAL OPTIONS

Volts	Amps	Breaker	kW	Wires	Phase
120/60Hz	6.8	10	.9	2	1
220/60Hz	7.2	10	1.7	2	1
220/50Hz	7.2	10	1.7	2	1
220/50Hz	7.2	20	1.7	2	1
240/50Hz	7.2	10	1.7	2	1
240/50Hz	7.2	20	1.7	2	1

OPERATING PRESSURE

Operating PSI	12 psi
Safety Release PSI	15 psi

GAS OPTIONS

	Btu/hr	Inlet Pressure
Natural Gas	90,000	4" W.C.
LP Gas	80,000	10.5" W.C.

INCLUDED ACCESSORIES

- 1 White pot scrubber brush
- 1 White drain brush
- 1 L-tipped brush
- 1 Long black brush
- 1 Short black brush
- 1 Bail handle basket
- 1 Pair 13" insulated mitts

GAS CONNECTION

3/4" NPT



Visit bkideas.com to view all accessories available for this model.