



36" MULTI-SHELF MERCHANDISER WITH FULL BASE – SELF-SERVE – CASCADING SHELVES

Model MDW-36-5CFM



MDW-48-5CFM shown.

The BKI® multi-shelf, self-serve hot food merchandiser creates a profit center by showcasing daily specials and deli offerings in an attractive grab-n-go display.

The MDW-36-5CFM is a 36" wide floor model with individually controlled heated shelves which allow you to set the optimum temperature for each shelf depending on the product. Every shelf is illuminated with a shatter-resistant fluorescent bulb.

Standard features include five energy-efficient heated and lighted cascading shelves, single glazed end walls, 2" front and side bumpers, and stainless steel shelf surfaces. Options include casters for mobility and pass-through sliding rear doors.

The MDW series of merchandisers are offered in 36" or 48" widths, cascading or 10"-20" deep vertical style shelves, 2-5 tiers of shelves, and countertop or full-base floor models. No matter your product volume or space available, we are sure to have a merchandiser to fit your needs.

FEATURES AT A GLANCE

- Energy-efficient heating technology provides uniform shelf temperature
- Electronic thermostat control on each shelf
- Stainless steel shelf surface is durable and easy to clean
- Single glazed end walls with attractive profile
- 100% hand built in the U.S.A.



PRODUCT CAPACITY

Holds up to 28 chicken domes for display depending on shelf configuration.



ELECTRIC OPERATION

Energy efficiency and easy installation are a perfect pairing for your food service operation.

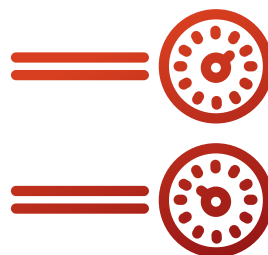

INDIVIDUAL TEMP. CONTROL

Control the temperature of individual shelves depending on product.



36" MULTI-SHELF MERCHANDISER WITH FULL BASE – SELF-SERVE – CASCADING SHELVES

Model MDW-36-5CFM

EQUIPMENT DIMENSIONS

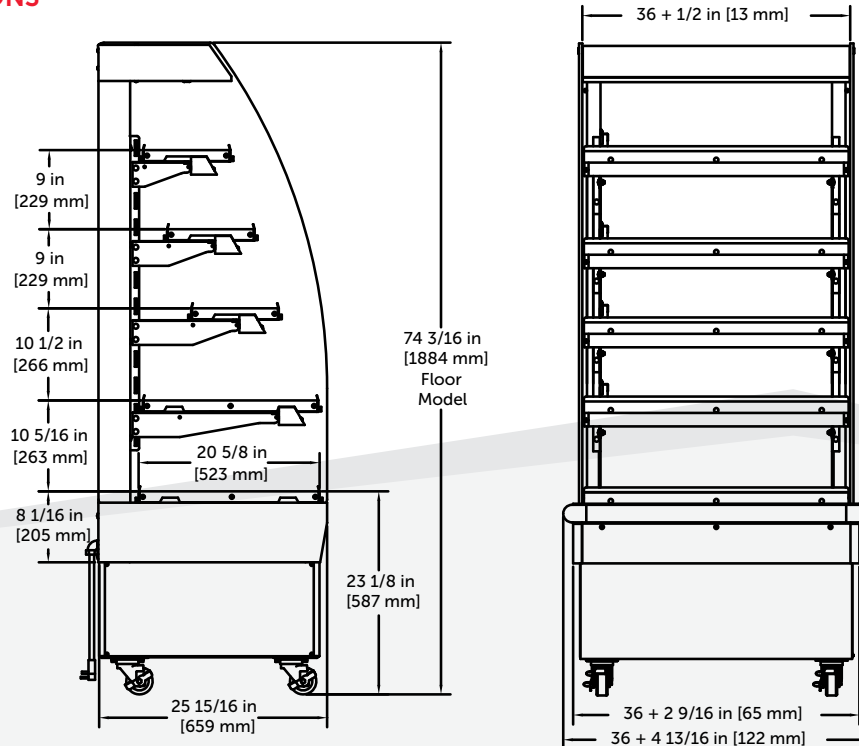

MECHANICAL SPECIFICATIONS

Dimension	Uncrated
Height	74 3/16" (1884 mm)
Width	36" (914 mm)
Depth	25 15/16" (658.8 mm)
Weight	720 lb (326.6 kg)

ELECTRICAL SPECIFICATIONS:

Volts	Breaker	kW	Amps
208	20	2.2	10.5
220	20	2.3	10.4
230	20	2.5	10.8
240	20	2.7	11.2

OPTIONS

- Pass-through sliding mirrored doors
- Casters for mobility



Visit bkideas.com to view all accessories available for this model.

5.20.2016

bkideas.com

© BKI LI0283C/08-06

Specifications are subject to change without notice.

BKI North America
 PO Box 80400
 Simpsonville, SC 29680-0400 USA
 Telephone: (864) 963-3471
 Toll Free: (800) 927-6887

