



HIGH-CAPACITY ROTISSERIE – SOLID BACK – TOUCHSCREEN CONTROLS – CURVED GLASS

# Model VGG-5-C



Ideal for supermarkets and high-volume restaurants, the BKI® VGG-5-C has a large cooking capacity that will meet growing customer demand and improve profitability. This rotisserie can cook up to up to 20 3-lb (1.36 kg) chickens in 75 minutes. The results are delicious—moist and tender inside and perfectly golden brown outside.

The bright touchscreen display makes operation a breeze with true one-touch cooking. Store up to 15 customizable menu programs that can be locked to protect important settings. Select English or Spanish with the new bilingual feature.

Innovative safety features include cool-door technology and sensors that stop rotation when the door is opened.

Whether poultry, pork, beef, vegetables, or your own specialty, the VGG-5-C is sure to maximize customer satisfaction and produce uniform, consistent results every time.



## FEATURES AT A GLANCE

- Touchscreen controls
- Curved glass doors
- Lighted cavity to attract customer attention
- Easy-to-clean interior
- Electric operation
- 15 program modes with pre-heat and hold capability
- Cool door for safety
- Solid back design
- 100% hand built in the U.S.A.



### PRODUCT CAPACITY

Cooks up to 20 3-lb (1.36 kg) chickens in 75 minutes at the touch of a button.



### ELECTRIC OPERATION

Energy efficiency and easy installation are a perfect pairing for your food service operation.



### TOUCHSCREEN CONTROLS

True one-touch process controls ensure menu items are perfectly cooked.



### COOL-DOOR SAFETY

Double doors insulate to prevent burns; sensors stop rotation and cooking when door is opened.



HIGH-CAPACITY ROTISSERIE – SOLID BACK – TOUCHSCREEN CONTROLS – CURVED GLASS

# Model VGG-5-C

## EQUIPMENT DIMENSIONS

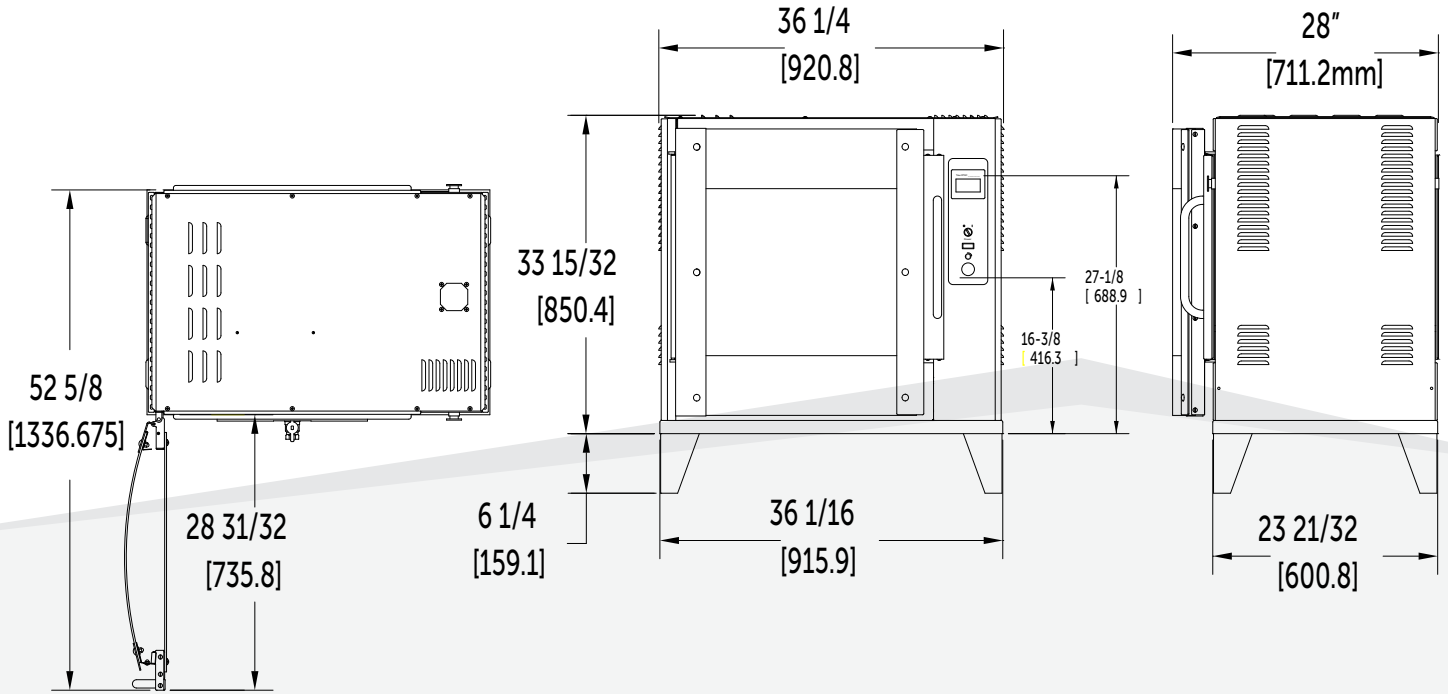

## MECHANICAL SPECIFICATIONS

Dimension	Uncrated
Height	39.75" (1080 mm)
Width	36.25" (921 mm)
Depth	28" (711 mm)
Floor Space	8.1 sq ft (.75 sq m)
Weight	430 lb (195 kg)

## ELECTRICAL OPTIONS

### NORTH AMERICA

Volts	Amps	Breaker	kW	Wires	Phase
208	29.3/17.2	40/25	6.1	2/3	1/3
220	23.5/13.8	30/20	5.2	2/3	1/3
240	27.8/16.3	40/25	7.1	2/3	1/3

### EUROPE

### 230 Volts, 50 Hz 3 Ph+N+E

	Current (A)	Power (W)
L1	9.3	2182
L2	9.3	2130
L3	9.2	2120

## OPTIONS

- Pass-through
- Flat glass
- Drain on drip pan

## CLEARANCES

	Combustible	Non-Combustible
Sides	6" (152.5 mm)	2" (51 mm)
Back	6" (152.5 mm)	2" (51 mm)



Visit [bkideas.com](http://bkideas.com) to view all accessories available for this model.

8.30.2017

bkideas.com

© BKI LI0283C/08-06

Specifications are subject to change without notice.

**BKI North America**  
 2812 Grandview Drive  
 Simpsonville, SC 29680  
 Telephone: (864) 963-3471  
 Toll Free: (800) 927-6887

Dimensions nominal.  
 Shipping Class: #110  
 FOB Simpsonville, SC

