



FIVE-WELL HOT CASE – INDEPENDENT TOP & BOTTOM HEAT CONTROLS – FLOOR MODEL

Model WDCG-5



Displaying and holding your culinary masterpieces are just as important as the ingredients that go into the recipe. The BKI® WDCG-5 hot food merchandisers are designed to keep food at a precise temperature for long holding times while maintaining maximum freshness.

The WDCG series of hot cases come standard with the user-friendly touchscreen system, which allows for independently controlled top and bottom heat as well as control for each food well. This give you the flexibility to heat a wide variety of foods at their optimum temperatures.

Built with the real world in mind, our hot cases include recessed, shatter-resistant fluorescent upper lighting, front glass that lifts up and locks for easy cleaning access, and a fold-down and removable cutting board.

The BKI WDCG series of hot cases have the widest range of display configurations of any hot cases on the market including full-service or self-service, curved or straight glass, drop-in pan or flat surface warmer configurations, countertop or floor models, and/or combinations of all of the above. There is bound to be the perfect combination to fit your needs.

FEATURES AT A GLANCE

- Touchscreen control provides precise temperature
- 28" Stainless steel base
- Full-service glass
- Full-service 5" deep wells
- Glass end panels
- Front bumper
- Rear service doors available in mirrored or clear glass
- Front glass lifts up and locks for cleaning access
- Fold-down, removable cutting board
- 100% hand built in the U.S.A.



FIVE WELLS

Independently controlled heated wells allow various foods to be held at optimal temperatures.



TOUCHSCREEN CONTROLS

Touchscreen controls ensure food is kept at optimal temperatures.

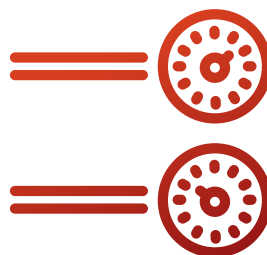

INDIVIDUAL TEMP. CONTROL

Independently controlled top and bottom heat as well as control for each food well.



FIVE-WELL HOT CASE – INDEPENDENT TOP & BOTTOM HEAT CONTROLS – FLOOR MODEL

Model WDCG-5

EQUIPMENT DIMENSIONS

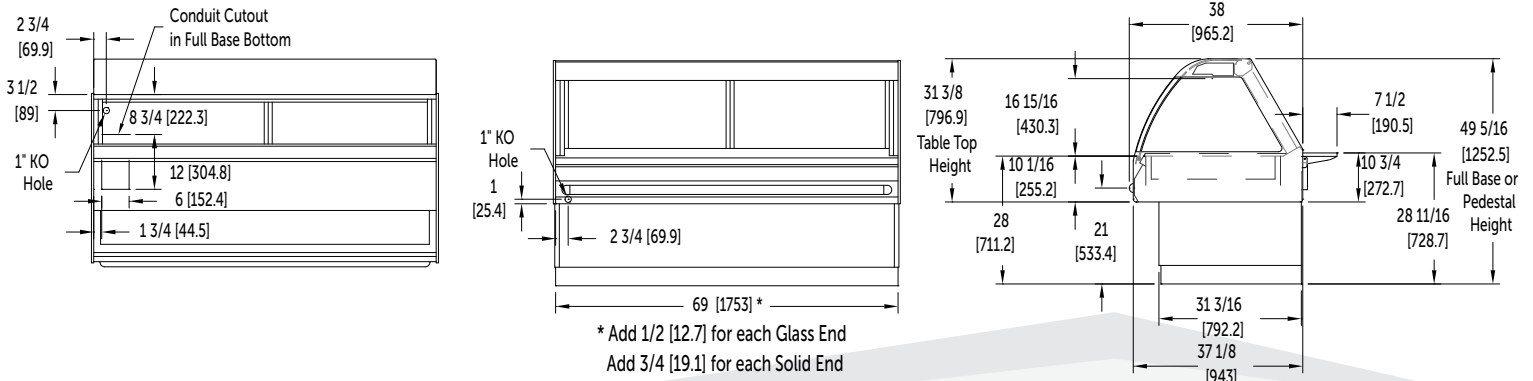

WELL CONFIGURATIONS

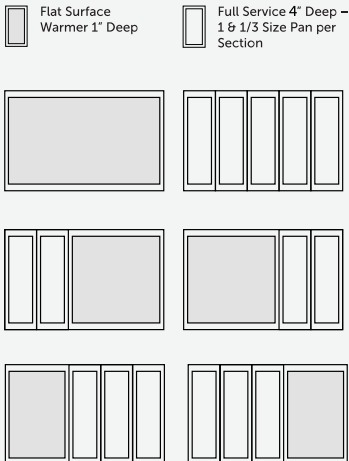

ELECTRICAL OPTIONS

Volts	Amps	Breaker	kW	Wires	Phase
208	20.4/33.1	30/45	6.9	3/2	3/1
220	17.2/27.1	25/35	5.8	3/2	3/1
240	18.6/29.4	25/40	7.1	3/2	3/1
230/400	10.8/28.0	15/35	6.4	4/2	3/1
240/415	11.4/29.2	15/40	7.0	4/2	3/1

MECHANICAL SPECIFICATIONS

Dimension	Uncrated
Height	49 5/16" (1252.5 mm)
Width	69 1/2" (1765.7 mm)
Depth	38" (965.2 mm)
Floor Space	18.2 sq ft (1.7 sq m)
Weight	695 lb (315 kg)



Visit bkideas.com to view all accessories available for this model.

5.20.2016

bkideas.com

© BKI LI0283C/08-06

Specifications are subject to change without notice.

BKI North America
PO Box 80400
Simpsonville, SC 29680-0400 USA
Telephone: (864) 963-3471
Toll Free: (800) 927-6887

