



VITROCERAMIC INFRARED CONCEPT

VITRO SPEED GRILLS (VG)

- Ideal for out-front display cooking, banquets and catering
- Rapid cooking with combined infrared radiant and contact heat
- Heavy duty vitroc ceramic cooking plates available with ribbed top and smooth bottom or smooth top
- Non-porous plate surface assures easy cleaning and prevents carbon build up
- Perfectly counterbalanced top plate effectively accommodates wide range of products
- Thermostatically controlled up to 570°F with fast preheating and even heat distribution
- Highly portable and convenient operation
- Stainless steel body with front grease drawer
- Extra high-power output on 208/240V models
- Robust heavy-duty construction
- Three position electronic timer
- Faster preheat and cook times

PANINI-VG

208/240 V



120 V

DIABLO-VG

208/240 V



VITROCERAMIC SERIES (VC)

MAJESTIC VC

208/240 V



*standard construction
 *optional mechanical timer only

PVC400

120 V



*on/off switch
 *internal drip tray
 *temperature up to 570°F



100 NIANTIC AVENUE; SUITE 104 PROVIDENCE, RI 02907
 TEL: (401)273-3300 FAX: (401)273-3328 E-mail: sales@equipex.com
 www.equipex.com



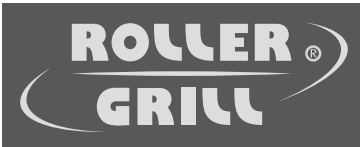

INFRARED PANINI PRESSES & GRIDDLE

PANINI-VG

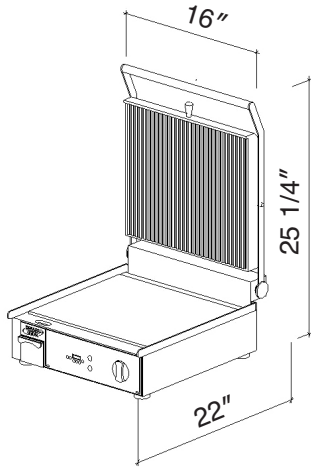

DIABLO-VG

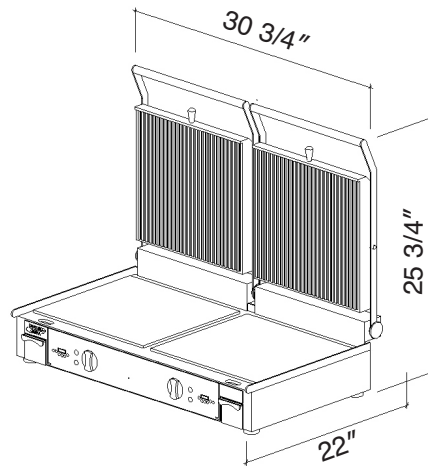

MAJESTIC VC

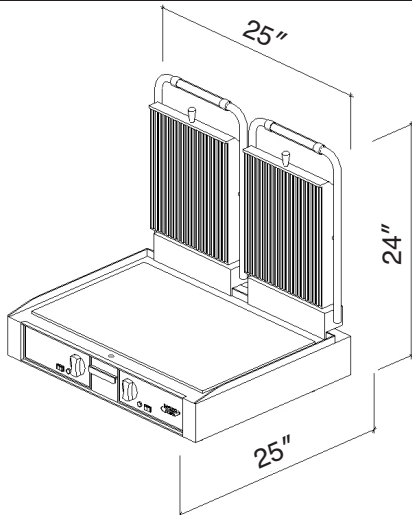

PVC 400

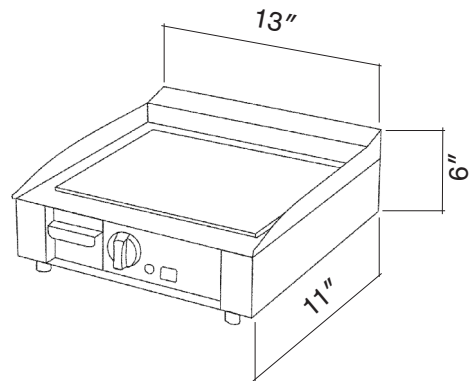

SPECIFICATIONS

MODEL	ELECTRICAL	DIMENSIONS	WORK SURFACE	SHIPPING WEIGHT	NEMA
PANINI VG	120V, 1PH, 1.75KW, 14Amps 208/240V, 1PH, 3.0KW, 12/14Amps	16"Wx22"Dx25 1/4"H	13 1/4"Wx12"D	50 lbs	5-15P 6-20P
DIABLO VG	208/240V, 1PH 6.0KW, 22/25Amps	30 3/4"Wx22"Dx25 3/4"H	(2) 13 1/4"Wx12"D	68 lbs	6-50P
MAJESTIC VC	208/240V, 1PH 3.3KW, 12/14Amps	25"Wx25"Dx24"H	22 1/2"Wx9 3/4"D	48 lbs	6-20P
PVC 400	120V, 1PH 1.75KW, 14Amps	16"Wx17"Dx6"H	13"Wx11"D	21 lbs	5-15P

WARRANTY: Limited one year parts and labor



100 NIANTIC AVENUE; SUITE 104 PROVIDENCE, RI 02907
 TEL: (401)273-3300 FAX: (401)273-3328 E-mail: sales@equipex.com
 www.equipex.com