

TURBO DISPLAY CASE

C O N C E P T

HEATED DISPLAY CASE COUNTERTOP WITH CURVED FRONT

*Combines uniform air pattern with
enhanced product visibility*

- Stainless steel base construction
- Overhead LED light for better visibility
- Curved front lift up see-through plexiglass door
- Rear lift up plexiglass serving door
- Modular design with detachable heater
- Unique convection enhanced air pattern
- Thermostatically controlled up to 200°F
- Stainless steel slotted upper shelf
- Bottom removable tray for easy cleaning

SPECIFICATIONS

REVELATION

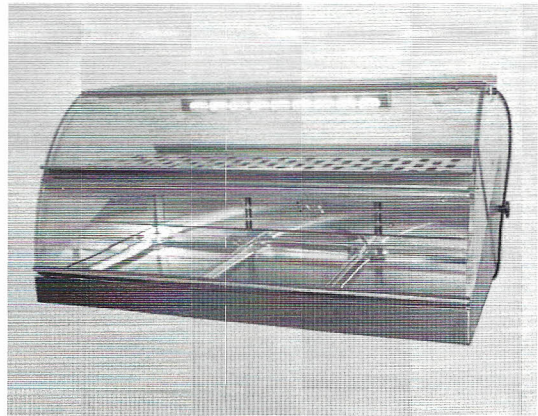

VHC 1000

120 V

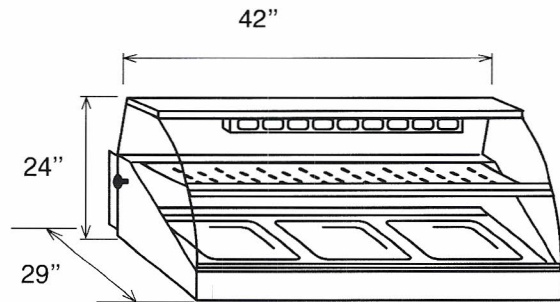

MODEL	ELECTRICAL	EXTERIOR DIMENSIONS	DISPLAY SURFACE DIMENSIONS PAN CAPACITY	SHIP WEIGHT	NEMA PLUG
VHC 1000	120V, 1800W, 15 Amps	42"Wx29"Dx24"H (add 4" for legs)	Upper Shelf: 36"Wx12"D (3) 12"x10"x2 ¹ / ₂ "pans Bottom Shelf: 36"Wx21"D (3) 12"x20"x4"pans	220 lbs	5-15 P (U.S.) 5-20 P (Can)

WARRANTY: Limited one year parts and labor



765 WESTMINSTER STREET PROVIDENCE, RI 02903
 TEL: (401)273-3300 FAX: (401)273-3328 E-mail:sales@equipex.com
 www.equipex.com