

CFS22 & CFS22-1.5

Application

- Multipurpose

Water Filtration Systems

Spec No. _____

Quantity _____



CFS22

Product Features

- ◆ 1" and 1-1/2" NPT inlet and outlet connections allow high flow rates for point-of-entry applications.
- ◆ Built-in pressure relief button relieves internal pressure for convenient cartridge change-outs.
- ◆ Pressure tested high impact plastic design withstands pressure surges and water hammer.
- ◆ FDA CFR-21 and/or NSF compliant materials provides peace of mind that this product is suitable for potable applications.
- ◆ Filter wrench included.

CUNO's CFS22 Series high flow filter housings allow installation either at the point-of-entry or the point-of-use. The low pressure drop across the system ensures adequate water flow and pressure to all equipment. Various media options are available for both sediment and chlorine taste and odor reduction.

Product Specifications

Model Number	Part Number	Description	Flow Rate	Cartridge Options
CFS22	56067-04	Opaque, 20" Length 1" NPT Connections	45 gpm max (170.3 lpm) 10 gpm (37.8) w CFS215-2	CFS210-2 CFS211-2 CFS212-2
CFS22-1.5	56067-05	Opaque, 20" Length 1.5" NTP Connections	60 gpm max (227.1 lpm) 10 gpm (37.8) w CFS215-2	CFS214-2 CFS215-2



Water Filter Systems

Foodservice

CFS22 & CFS22-1.5 Water Filtration Systems

Spec No. _____
 Quantity _____
 Model Number _____
 Part Number _____

Installation Tips:

- Shut off downstream equipment prior to installation of the system.
- Do not exceed operating parameters for temperature or pressure.
- For cold water use only.
- For commercial use only.

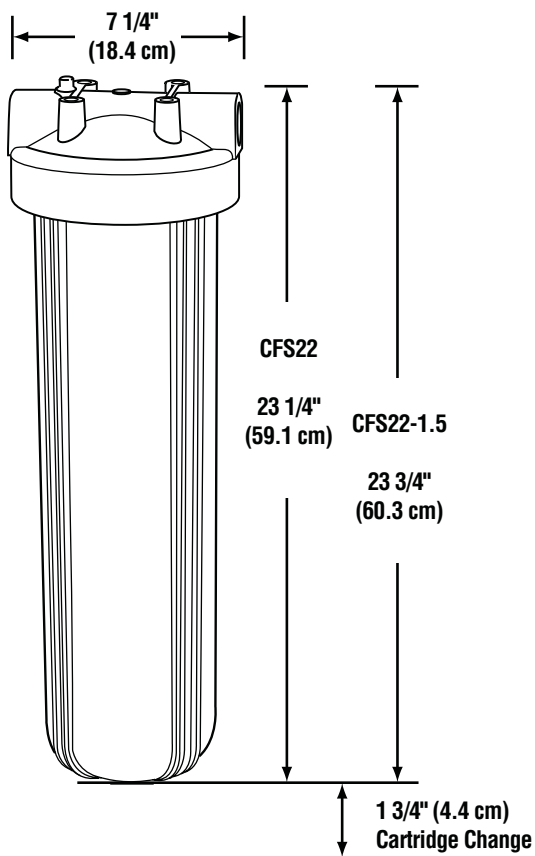

Do not use with water that is microbiologically unsafe or of unknown quality without adequate disinfection before or after the system.

CUNO Incorporated recommends regularly scheduled maintenance and replacement of the filter cartridge(s) in order for the product to perform as advertised/sold.

Accessories

Model Number	Part Number	Description
CFS22MB	68901-31	Mounting Bracket

Limited 5 Year Warranty

CUNO Incorporated warrants to the original purchaser-consumer that this product is free from defects in materials and workmanship. This warranty, together with any and all warranties implied by law, shall be limited to a period of five (5) years from the date of original purchase by the consumer. This warranty does not apply to failures that result from abuse, misuse, alteration or damage not caused by CUNO. This warranty is subject to exclusions and limitations. Please refer to the Warranty Card provided with the product for details.

Service Worldwide

China
 CUNO Filtration Shanghai Co. Ltd.
 No. 2 Plant East Side
 Xin Miao San Road
 XinQiao Town SongJiang District
 Shanghai, China 201612

Australia
 CUNO Pacific Pty Ltd.
 140 Sunnyholt Road
 Blacktown, N.S.W. 2148
 Australia

Europe
 CUNO Limited
 21 Woking Business Park
 Albert Drive
 Woking, Surrey
 GU21 5JY, England



Japan
 CUNO K.K.
 Hodogaya Station Building 6F
 1-7, Iwai-Cho, Hodogaya-Ku
 Yokohama 240-0023, Japan

Brazil
 CUNO Latina Ltda
 Rua AMF do Brazil - 251
 18120 Mairinque-SP, Brazil

Singapore
 CUNO Filtration Asia Pte Ltd
 18 Tuas Link 1
 3rd Floor
 Singapore 638599

CUNO Incorporated
 400 Research Parkway
 Meriden, CT 06450, USA
 Toll Free: 1-888-218-CUNO
 Worldwide: 203-237-5541
 Fax: 203-238-8701