

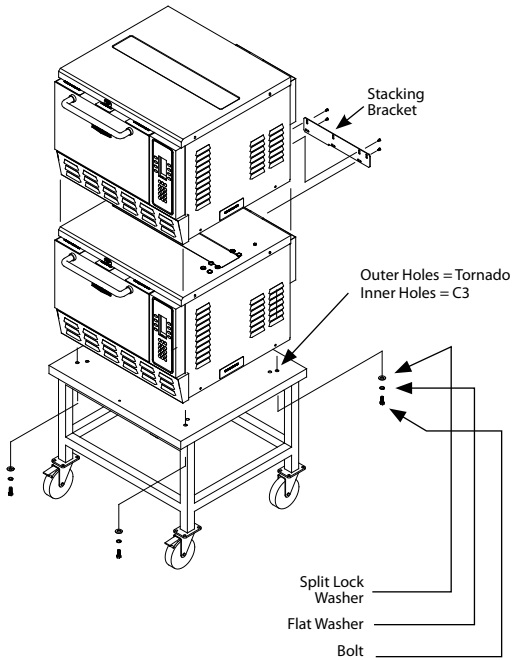

Securing Tornado, C3, and High h Batch Ovens to an Oven Cart

Tornado or C3 (Figure 1)



FOR ALL OVENS:

1. Unplug the oven.
2. Lock the wheels of the oven cart.

NOTE: For additional skid prevention of C3 and Tornado ovens, place a TurboChef sorbothane stacking mat (part number NGC-1342-1) on the cart, aligning the edges of the mat with the edges of the cart.

3. Place the oven on the oven cart.

- ⚠ WARNING: Do not attempt to lift the oven with fewer than 2 people.
- ⚠ WARNING: When lifting, position at least one person on each side.
- ⚠ WARNING: Do not lift the oven from the front and back.
- ⚠ WARNING: Do not lift the oven by the door handle.

FOR TORNADO & C3 ONLY: (FIGURE 1)

4. If the oven is a C3 or Tornado, remove the legs. There will be holes in the oven where the legs used to be.
5. Align the oven holes with the oven cart holes. (Different sets of holes are provided on cart to accommodate either the Tornado or C3 - see Figure 1.)
6. Install bolts with washers by running them up through the cart surface and into the holes in the oven (where the legs were).

FOR HIGH H BATCH: (FIGURE 2)

4. Attach one oven cart bracket to each leg (part number HHB-8206 includes four brackets).
5. Secure each leg by aligning the bracket with the holes on the oven cart and attaching the parts listed in Figure 2.

NOTE: Ensure the nut is securely tightened.

High h Batch (Figure 2)

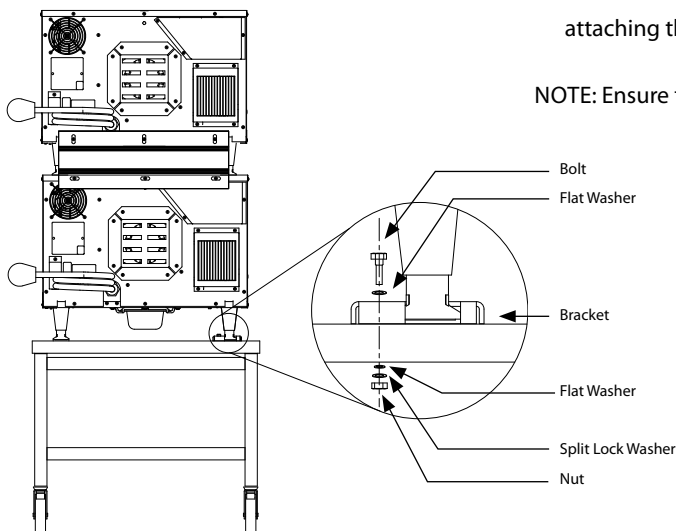

TurboChef Global Operations
 4240 International Pkwy, Suite 105
 Carrollton, Texas 75007 USA
 US: 800.90TURBO (800.908.8726)
 International: +1 214.379.6000
 Fax: +1 214.379.6073
 turbochef.com



Stacking Tornado, C3, and High h Batch Ovens

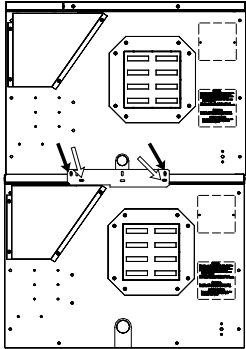

Option 1: Tornado/Tornado

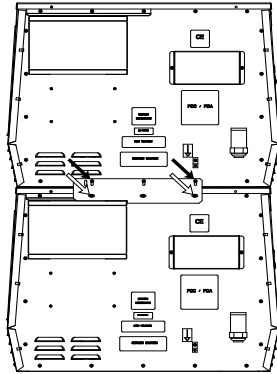

Option 2: C3/C3

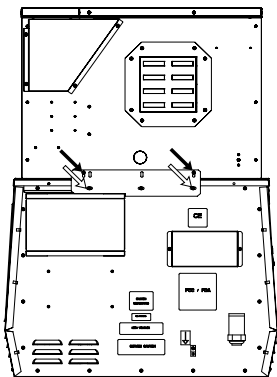

Option 3: Tornado/C3

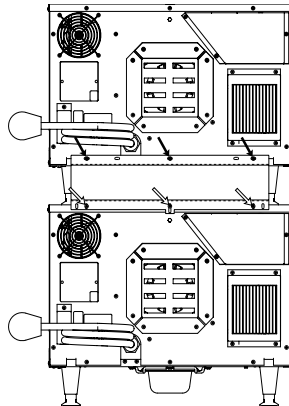

Option 4: HHB/HHB

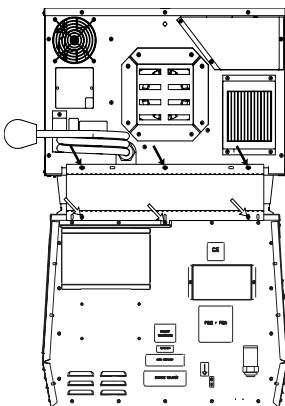

Option 5: HHB/C3

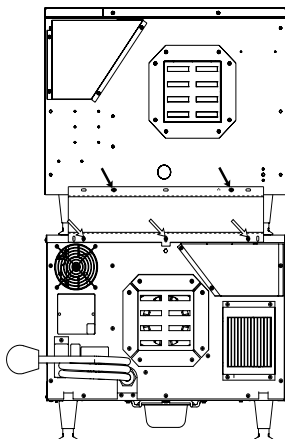

Option 6: Tornado/HHB

1. Ensure the surface that will hold the stacked ovens can support the total weight plus the intended use. Each High h Batch: 157 lbs. (71 kg), each Tornado: 190 lbs. (86 kg), each C3: 255 lbs. (116 kg).
2. Allow each oven adequate time to cool and then unplug.
3. If stacking the ovens on an oven cart, ensure the bottom oven is bolted to the cart and the wheels are locked (see reverse side of sheet).
4. Attach the stacking bracket* to the back of the bottom oven:
 - a. Remove the screws marked with white arrows in the adjacent figures.
 - b. Align the holes on the stacking bracket with the holes on the oven and reinstall the screws. Be sure to orient the bracket as shown in the adjacent figures.

* Options 1-3 use bracket part number TC3-0323.
Options 4-6 use bracket part number HHB-8165.

5. If the top oven is a Tornado or C3, remove the legs. This requires two or more persons—at least one to lift and one to unscrew the legs.
- ⚠ DO NOT REMOVE THE LEGS IF THE TOP OVEN IS A HIGH H BATCH.
6. Remove the screws from the oven that will be placed on top, as marked with black arrows in the adjacent figures.

7. Place the top oven on the bottom oven.
- ⚠ WARNING: Do not attempt to lift the oven with fewer than 2 people.
 ⚠ WARNING: When lifting, position at least one person on each side.
 ⚠ WARNING: Do not lift the oven from the front and back.
 ⚠ WARNING: Do not lift the oven by the door handle.

8. Align the holes on the stacking bracket with the holes on the top oven and reinstall the screws.

⚠ WARNING: Do not stack ovens over two-high.

⚠ WARNING: Any stacking combinations not specified on this sheet will result in unsafe conditions.

TurboChef Global Operations
 4240 International Pkwy, Suite 105
 Carrollton, Texas 75007 USA
 US: 800.90TURBO (800.908.8726)
 International: +1 214.379.6000
 Fax: +1 214.379.6073
 turbochef.com



Stacking HhC 2020 Ovens

- ⚠ WARNING: DO NOT use this appliance without the legs installed on the bottom oven.
- ⚠ WARNING: Make sure all HhC 2020 ovens are unplugged before stacking.
- ⚠ WARNING: DO NOT stack ovens more than 3 high.
- ⚠ WARNING: DO NOT attempt to lift the oven with fewer than 2 people.

1. Remove the legs from the oven(s) that are going to be stacked on top.
2. Cover the leg holes with the abrasive pads provided with kit HCT-3001.
- 3a. If the front panel on each oven contains side hinges, skip to step 4.
- 3b. If the front panel on the ovens that are going to be stacked on top contain bottom hinges (adjacent), ensure that a thumb screw is installed on each side to allow for front panel removal. If the oven has security screws, replace them with the thumb screws provided with kit HCT-3001.
4. Stack the top oven on the bottom oven. If stacking three ovens, stack only the middle oven at this point.
5. Remove the 6 screws marked A or B in the illustration below.
6. Align each bracket with the holes in the bottom oven and reinstall the screws marked A in the illustration below.
7. Align each bracket with the holes in the top oven and reinstall the screws marked B in the illustration below.
8. If stacking three ovens, repeat steps 2-6 above to stack the top oven to the middle oven.
9. Ensure each stacked oven is secured to the oven beneath it via two stacking brackets – one on each side.

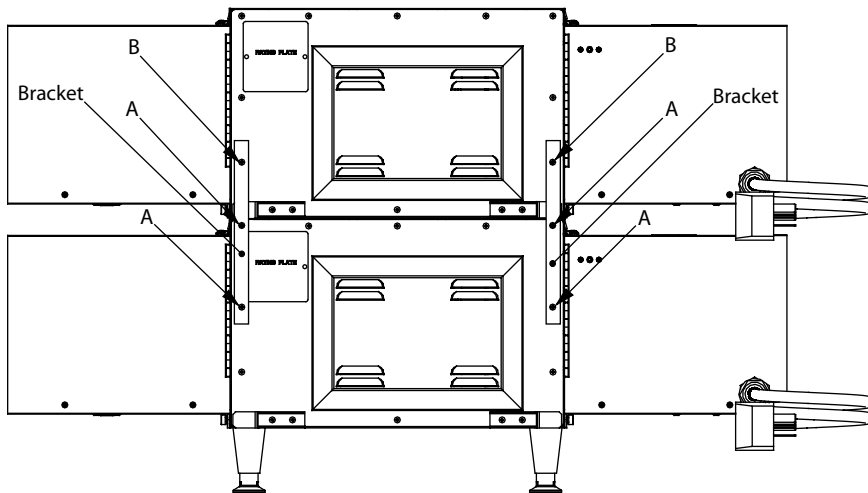
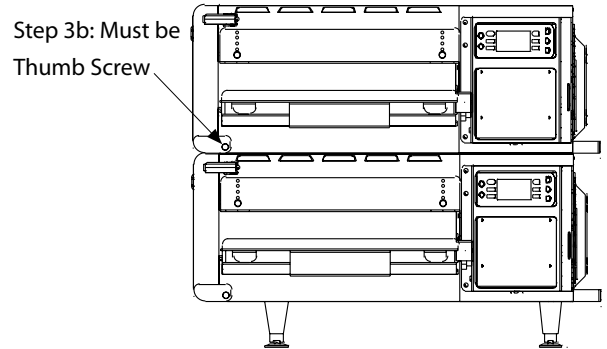

Stacking HhC 3240 Ovens

Follow all instructions in the Installation Manual (part number HHC-6651), included with each oven.



Stacking i3 and i5 Ovens

Reference the below illustrations for the proper stacking configuration, as well as dimensions.

1. Unplug each oven.
 2. Set the oven stand (part number i5-9369) in place.
- ⚠ WARNING: Do not attempt to lift the oven with fewer than 2 people.
 ⚠ WARNING: Position at least one person at the front and back of the oven and always use the hand grips when lifting.
 ⚠ WARNING: Do not lift the oven by the door handle.
3. Lock the wheels of the oven cart (part number NGC-1217-2).
 4. Place the lower oven on the oven cart.
 5. Place the top oven on the oven stand.
 6. Unlock the wheels of the oven cart and position it beneath the stand, as shown in the below illustration.

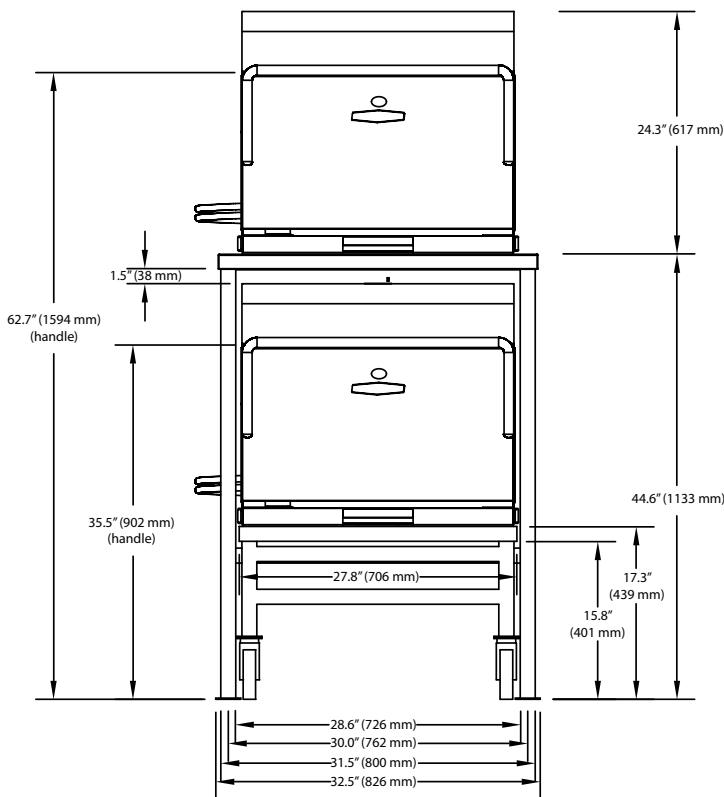
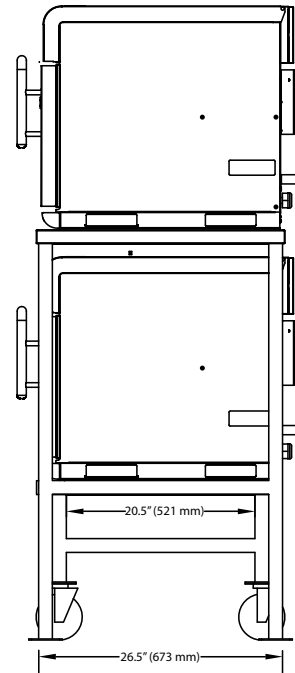

i5 Oven

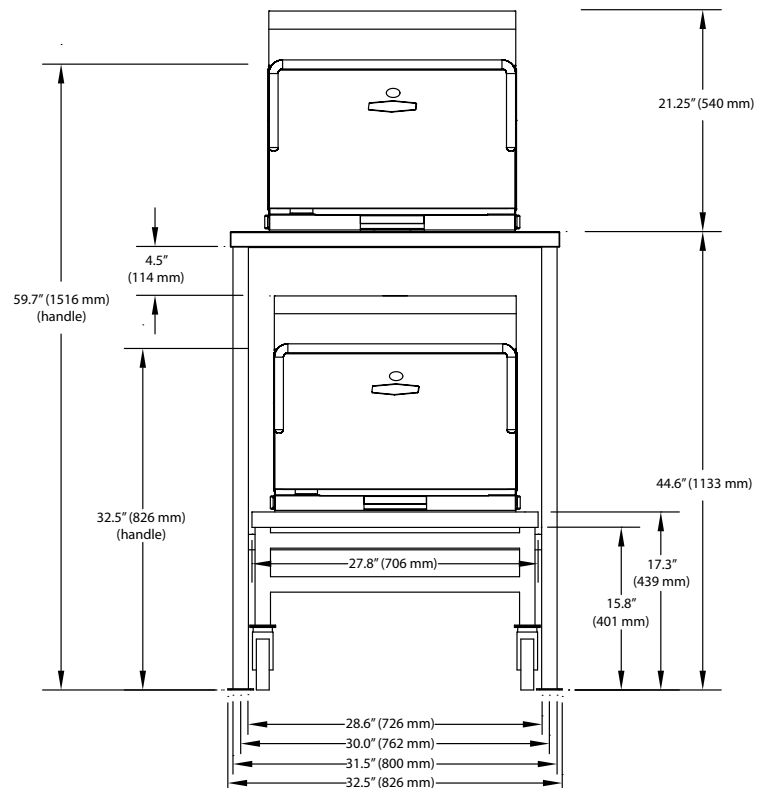

i3 Oven