

Project Name: _____ AIA#: _____

Model #: _____ Location: _____

SIS#: _____ Item #: _____ Quantity: _____



Chefmate® by Globe Countertop Soup Warmer

Increase your menu and sales by adding soup — just plug and serve!

Perfect for buffets, serving stations, prep areas.



Model

CPSKB1

Standard Features

- 400 watts, 120V for warming
- Thermostatically controlled with 12 temperature settings — 212°F max
- Over-heat protection with manual reset
- Attached 4.5-foot power cord & 5-15P NEMA plug
- Steel, black powder-coated body with aluminum lining
- Removable, stainless steel soup pot — 9.5 quart capacity
- Attached, stainless steel, hinged lid
- Stable round base with rubber feet
- Includes 13 food labels and 1 magnet

Warranty

- *One year parts and labor*

Optional Accessories/Attachments

SKP019 - Additional or replacement Labels

To select options see back



Important: please use only included stainless steel pot.
Do not use other inserts, pots or pans in this unit.

Approved by: _____ Date: _____

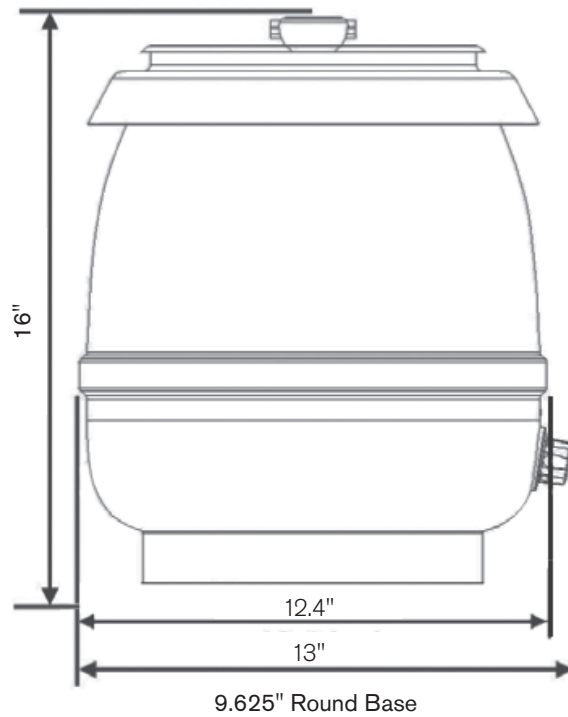

For Indoor Use Only

SPECIFICATIONS

Model	Capacity	Thermostat Controls	Temperature Settings	Cooking Temperature	Voltage	AMPs	Wattage	NEMA Plug Type
CPSKB1	9.5 Qts	1	1-12	Warm to 212°F (boiling) max temp	120	3.5	400W	5-15P (Ⓜ)

Multi Function Settings:

Heat: This function holds constant wattage for maintaining food, warm/hot, at a controlled temperature, 12 levels.

Thermostatically Controlled (12) Temperatures: This function controls cookware to a precise temperature for cooking, 12 different temperatures. This equipment is a warmer only, not a cooker.

Important: DO NOT operate warmer without at least 2.5 cups of water in warming base.

DIMENSIONS | SHIPPING INFORMATION

Carton reinforced for shipping. The weight and dimensions of reinforced carton are listed below and may vary from shipment to shipment. **Freight class 85**

Model	Overall Dimensions	Net Weight	Shipping Dimensions	Shipping Weight
CPSKB1	13" dia. x 16" h (33 cm x 40.64 cm)	10.94 lbs. (4.96 kg)	14" w x 14" d x 17" h (58 cm x 35 cm x 48 cm)	13 lbs. (5.89 kg)

ADDITIONAL ITEMS:

SKP019 Magnetic label holder (1) and 13 food labels

SKPA01 Stainless steel lid for warmer

SWBOWL Stainless steel inner pot