

- KDT-1000A       KDT-1000W       KDT-1000N
- KYT-1000A       KYT-1000W       KYT-1000N



# KT-1000 Ice Kube Machine



- Easy access to food zone with removal of two screws and lift-off door
- High-tech exterior with smudge and fingerprint resistant stainless-like finish
- White plastics in the food zone help identify areas needing cleaning
- Water shield, distribution tube, pump, floats, and trough removable by hand
- Available CleanAir™ pack controls the growth of bacteria and fungi that form slime and cause odors in the food zone

**WARRANTY:**  
 Ice Maker: 3 year Parts & Labor  
 Evaporator: 5 year Parts & Labor  
 Compressor: 5 year Parts & 3 year Labor



**HALF KUBE**  
 $\frac{3}{8}'' \times 1\frac{1}{8}'' \times \frac{7}{8}''$   
 (.95 x 2.86 x 2.22 cm)

= 100%



**KUBE**  
 $\frac{7}{8}'' \times \frac{7}{8}'' \times \frac{7}{8}''$   
 (2.22 x 2.22 x 2.22 cm)

= 100%

Refrigerant R410A



**KT-1000**  
ICE KUBE MACHINE

*Koolaire KT-1000 Ice Kube Machine on a K570 bin.*

*Both ice machine and bin are AHRI certified.*



By MANITOWOC

2110 SOUTH 26TH ST | MANITOWOC, WI 54220 USA | 1-920-682-0161 | [www.kool-aire.com](http://www.kool-aire.com)



US LISTED



# KT-1000 ICE KUBE MACHINE

Model	Icon 1	Icon 2	24h		[kWh/100 lbs ice]	[gal/100 lbs ice]
			70°/50°F 21°/10°C	90°/70°F 32°/21°C		
KDT-1000A			890 lbs	680 lbs	5.35	20.0
			404 kg	308 kg		
KYT-1000A			960 lbs	775 lbs	4.9	20.0
			435 kg	362 kg		
KDT-1000W			835 lbs	720 lbs	4.35	20.0
			379 kg	327 kg		
KYT-1000W			860 lbs	730 lbs	4.25	20.0
			390 kg	331 kg		
KDT-1000N*			850 lbs	700 lbs	5.3	20.0
			386 kg	318 kg		
KYT-1000N*			930 lbs	760 lbs	5.2	20.0
			422 kg	345 kg		

\* Remote condenser JCT1200 must be ordered with "N" models

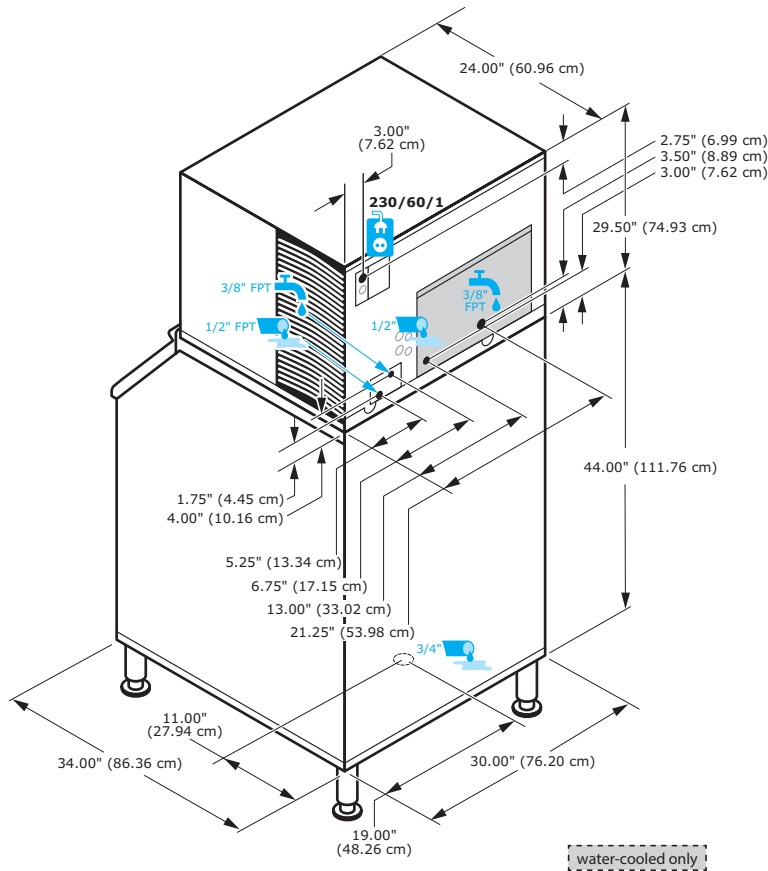

Minimum	Maximum
40°F 4.4°C	110°F 43.3°C
40°F 4.4°C	90°F 32.2°C
20psi 138 kPa	80psi 551 kPa
10.8 10.1 9.8	A
	15 Amps
215 lbs 215 lbs 237 lbs	97 kg 97 kg 108 kg

Water cooled condenser water usage/ 100lbs or 45.4kgs. of ice: 140 gals/530 L.

Popular Accessories			
Artic Pure Water Filters AR-Pre & AR 20000	Dispenser Bin Thermostat Kit K-00457	Top Air Discharge Kit K-00449	Clean Air Pack K-00206

## KOOLAIRE

By MANITOWOC

2110 SOUTH 26TH ST | MANITOWOC, WI 54220 USA | 1-920-682-0161 [ [www.kool-aire.com](http://www.kool-aire.com) ]