

- KDT-1700A KDT-1700W KDT-1700N
- KYT-1700A KYT-1700W KYT-1700N



KT-1700 Ice Kube Machine



- Easy access to food zone with removal of two screws and lift-off door
- High-tech exterior with smudge and fingerprint resistant stainless-like finish
- White plastics in the food zone help identify areas needing cleaning
- Water shield, distribution tube, pump, floats, and trough removable by hand
- Available CleanAir™ pack controls the growth of bacteria and fungi that form slime and cause odors in the food zone

WARRANTY:

Ice Maker: 3 year Parts & Labor
 Evaporator: 5 year Parts & Labor
 Compressor: 5 year Parts & 3 year Labor

KT-1700
ICE KUBE MACHINE



HALF KUBE
 $\frac{3}{8}'' \times 1\frac{1}{8}'' \times \frac{7}{8}''$
 (.95 x 2.86 x 2.22 cm)

❄️ = 100%
 💧



KUBE
 $\frac{7}{8}'' \times \frac{7}{8}'' \times \frac{7}{8}''$
 (2.22 x 2.22 x 2.22 cm)

❄️ = 100%
 💧

Koolaire KT-1700 Ice Kube Machine on a K970 Bin.

Both ice machine and bin are AHRI certified.



Model	Compressor	Ice Type	24h		Energy [kWh/100 lbs ice]	Water [gal/100 lbs ice]	ENERGY STAR
			70°/50°F 21°/10°C	90°/70°F 32°/21°C			
KDT-1700A	Fan	8.5g	1800 lbs	1350 lbs	4.6	20.0	
			816 kg	612 kg			
KYT-1700A	Fan	5.7g	1800 lbs	1380 lbs	4.6	20.0	
			816 kg	626 kg			
KDT-1700W	Water	8.5g	1765 lbs	1460 lbs	3.5	20.0	
			800 kg	662 kg			
KYT-1700W	Water	5.7g	1815 lbs	1550 lbs	3.4	20.0	
			823 kg	703 kg			
KDT-1700N*	Remote	8.5g	1680 lbs	1420 lbs	4.3	20.0	
			762 kg	644 kg			
KYT-1700N*	Remote	5.7g	1745 lbs	1490 lbs	4.0	20.0	•
			792 kg	676 kg			

* Remote condenser JCT1500 must be ordered with "N" models

KT-1700 ICE KUBE MACHINE

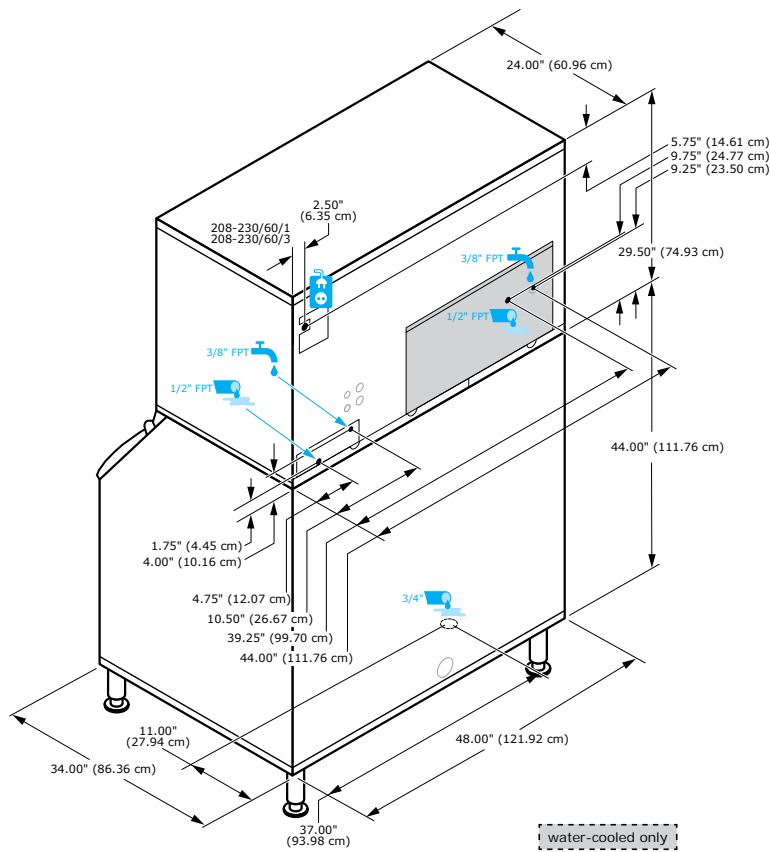

Water-cooled condenser water usage /100 lbs or 45.4 kgs. of ice: 140 gal/530 L.

Minimum	Maximum
40°F 4.4°C	110°F 43.3°C
40°F 4.4°C	90°F 32.2°C
20psi 138 kPa	80psi 551 kPa
18.2/13.6	A
16.8/12.2	
17.8/13.2	
30 Amp Single Phase 20 Amps 3 Phase	
296 lbs 134 kg	
298 lbs 135 kg	
303 lbs 137 kg	

KOOLAIRE
By MANITOWOC

2110 SOUTH 26TH ST | MANITOWOC, WI 54220 USA | 1-920-682-0161 [www.kool-aire.com]