

MODEL: IRT-MR41EN UNDERCOUNTER: Pizza Prep Tables



General Strengths

- ✓ **Sanitation.** The interior cabinet is built with rounded corners (extensive radius for easy cleaning). Quick ability to take off shelves and slides for interior cleaning. Each cabinet has a drain at the bottom of the unit. When cleaning the unit make sure the drain hose is routed to a floor drain.
- ✓ **Doors.** Self-closing door system with permanent pressure. Stay open feature included when door remains open after 95 degrees. All doors and drawers include triple chamber door gaskets, easy to remove and snap in. Doors are field reversible.
- ✓ **Control systems.** Higher precision in managing temperature settings. The ability to adjust temperature ranges to meet end user's requirements.
- ✓ **100% Tested.** All condenser units are 100% tested, in helium chambers in order to detect refrigeration leaks.
- ✓ **Certified.** Audited and Certified by **INTERTEK** for compliance with UL 471 and NSF 7. AENOR audited and certified by internationally recognized firm. ISO 9001:2008 (Quality); ISO 14001:2004 (Environmental); OSHAS 18001:2007 (Prevention and Worker Safety)



Two opening position linge



18" Work deep



Extraible shelf

MODEL	Dimensions (inches) (mm)			N° Door /Pans	N° Shelves/ Lids	Ref.	Ref. Weight (Lbs.) (gr.)	Temp. Range (°F) (°C)	Capacity (Cu. Ft.) (L)	Cond. Unit. H.P.	Case Amps 115 V.	Crated Weight (Lbs.) (Kg.)
	W	D	H									
IRT-MR41EN	41-3/8 1050	36-5/8 931	40-3/8 1025	1 / 5	2 / 1	R134a	0.62 280	35°F/41°F +2°C / +5°C	7.8 220	1/3	5.9	362 164

ETL LISTED TO UL471 STANDARD AND SANITATION CLASSIFIED TO NSF7 – WE RESERVE THE RIGHT TO CHANGE SPECIFICATIONS WITHOUT PRIOR NOTICE

MODEL: IRT-MR41EN
**UNDERCOUNTER:
Pizza Prep Tables**
STANDARD FEATURES
➤ Exterior

- AISI 304 Stainless Steel Top,
- AISI 430 Stainless Steel.

➤ Interior

- AISI 430 Stainless Steel,
- Internal drain plug for easy cleaning,
- Sealed interior floors and rounded cabinet corners.

➤ Insulation

- CFC-Free polyurethane insulation, entire cabinet structure is foamed-in place using a high density polyurethane insulation,
- Low GWP & Zero ODP effect.

➤ Doors

- Polyurethane insulated doors,
- Self-closing doors with stay open feature,
- Stainless Steel heavy-duty hinges,
- Triple chamber snap in door gaskets for easy removal and cleaning,
- Field reversible doors,
- Door locks,
- Full-height door opening: 21-5/8"x20-5/8" (550x523 mm).

➤ Casters

- 4" diameter casters,
- Locks provided on front set.

➤ Salad Top

- Stainless Steel insulated lid,
- Top includes 1/3 size polycarbonate food pans (5 pans),
- Pan divider bars included,
- Removable sanitary polyethylene cutting board included.

➤ Shelving

- (2) Plastic coated wire shelves per section,
- Set of Stainless Steel shelf brackets,
- Easy remove for cleaning,
- Dimensions WxD: 20-7/8"x25-5/8" (GN 2/1) (530x650 mm),
- Compatible with 18"x26" (457x660 mm) sheet pans.

➤ Refrigeration

- Digital temperature controller with automatic defrost system,
- Energy-saving non- electric condensate pan,
- Forced air refrigeration system,
- Extractable condensing unit for easy service,
- Evaporator coil coated with anti-corrosion material 100% Polyester,
- Refrigeration capacity: 1706 Btu/h (14°F) / 500 W (-10°C).

➤ Electrical

- Cord and NEMA 5-15P plug.
- Electrical connection is 115V / 1ph / 60 Hz.

➤ ETL Listed to UL471 Standard and Sanitation classified to NSF7.
OPTIONAL FEATURES

- ✓ Set of 6" legs, height adjustable from 5" to 8",
- ✓ Electrical connection is: 220-230 V / 1ph / 50 Hz (plug type varies),
- ✓ Stainless Steel wire shelves,
- ✓ Additional slide kits,
- ✓ Single Overshelf,
- ✓ Double Overshelf,
- ✓ Drawer Kit: 25-1/8"x28-3/8"x11-3/4" (638x720x300 mm).

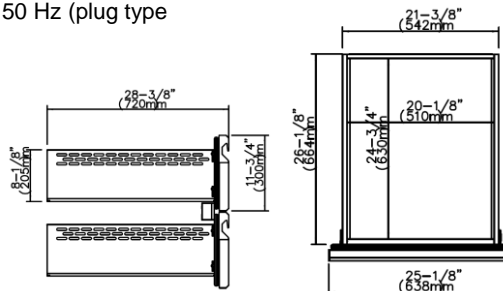

ETL LISTED TO UL471 STANDARD AND SANITATION CLASSIFIED TO NSF7 – WE RESERVE THE RIGHT TO CHANGE SPECIFICATIONS WITHOUT PRIOR NOTICE



Infrico USA Corp.
7042 N.W. 46th Street
Miami, FL 33166
1.305.777.9599 Office
1.305.777.9598 Fax

www.infrico.us
service@infrico.com
sales@infrico.com

APPROVALS: AVAILABLE AT:

MODEL: IRT-MR41EN

**UNDERCOUNTER:
Pizza Prep Tables**

PLAN VIEW

ELEVATION

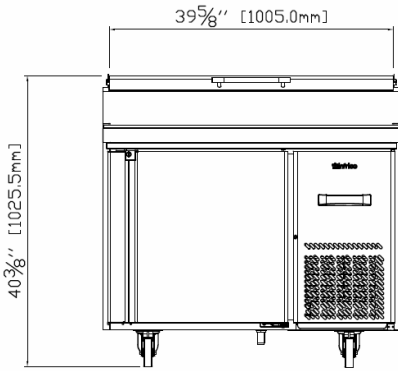

RIGHT VIEW

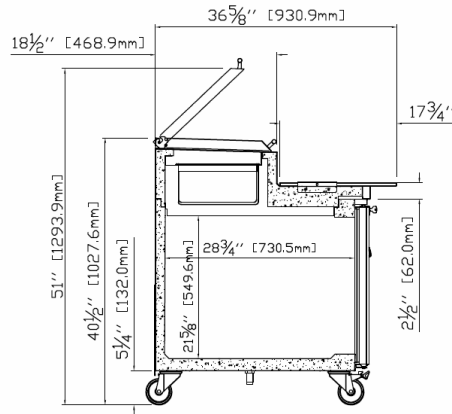

PLAN VIEW

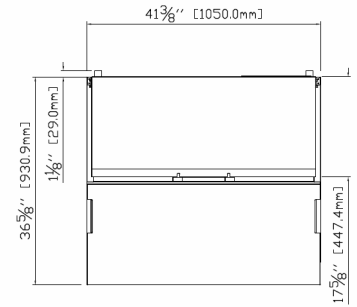

ETL LISTED TO UL471 STANDARD AND SANITATION CLASSIFIED TO NSF7 – WE RESERVE THE RIGHT TO CHANGE SPECIFICATIONS WITHOUT PRIOR NOTICE