



Project: _____

Location: _____

Item #: _____ Quantity: _____

Model #: _____

MODEL: IRT-UC72P **UNDERCOUNTER:**
Sandwich / Salad Prep Tables (Solid Doors)



General Strengths

- ✓ **Sanitation.** The interior cabinet is built with rounded corners (extensive radius for easy cleaning). Quick ability to take off shelves and slides for interior cleaning. Each cabinet has a drain at the bottom of the unit. When cleaning the unit make sure the drain hose is routed to a floor drain.
- ✓ **Doors & Drawers.** Self-closing door system with permanent pressure. Stay open feature included when door remains open after 95 degrees. All doors and drawers include triple chamber door gaskets, easy to remove and snap in. Doors are field reversible.
- ✓ **Control systems.** Higher precision in managing temperature settings. Greater ability to adjust temperature ranges as per the end user's requirement.
- ✓ **100% Tested.** All condenser units are tested 100%, in helium chambers to refrigerant leak detections.
- ✓ **Certified.** Audited and Certified by **INTERTEK** for compliance with UL 471 and NSF 7. AENOR audited and certified by internationally recognized firm. ISO 9001:2008 (Quality); ISO 14001:2004 (Environmental); OSHAS 18001:2007 (Prevention and Worker Safety)

MODEL	Dimensions (inches) (mm)			N° Doors/Pans	N° Shelves	Ref.	Ref. Weight (Lbs.) (gr.)	Temp. Range (°F) (°C)	Capacity (Cu. Ft.) (L)	Cond. Unit. H.P.	Case Amps 115 V.	Crated Weight (Lbs.) (Kg.)
	W	D	H									
IRT-UC72P	72-5/8	30-1/8	46-1/4	3 / 18	6	R134a	0.70	35°F/41°F	21	3/8	5.7	506
	1844	765	1175									

ETL LISTED TO UL471 STANDARD AND SANITATION CLASSIFIED TO NSF7 – WE RESERVE THE RIGHT TO CHANGE SPECIFICATIONS WITHOUT PRIOR NOTICE



Infrico USA Corp.
7042 N.W. 46th Street
Miami, FL 33166
1.305.777.9599 Office
1.305.777.9598 Fax

www.infrico.us
service@infrico.com
sales@infrico.com

APPROVALS: AVAILABLE AT:



Project: _____

Location: _____

Item #: _____ Quantity: _____

Model #: _____

MODEL: **IRT-UC72P**

UNDERCOUNTER:
Sandwich / Salad Prep Tables (Solid Doors)

STANDARD FEATURES

➤ **Exterior**

- AISI 430 Stainless Steel,
- AISI 304 Stainless Steel Top.

➤ **Interior**

- AISI 430 Stainless Steel.

➤ **Doors**

- Polyurethane insulated door,
- Self closing door with stay open feature,
- Stainless Steel heavy-duty hinges,
- Triple chamber snap in door gaskets for easy removal and cleaning,
- Field reversible door,
- Full-height door opening: 19-5/8"x21-7/8" (500x555 mm).

➤ **Insulation**

- CFC-Free polyurethane insulation, entire cabinet structure is foamed-in place using a high density polyurethane insulation,
- Low GWP & Zero ODP effect.

➤ **Casters**

- 4" diameter casters,
- Locks provided on front set.

➤ **Salad Top**

- Stainless Steel insulated lid,
- Top includes 1/6 size polycarbonate food pans, (18) pans,
- Pan divider bars included for varying size pan configurations,
- Removable sanitary polyethylene cutting board included.

➤ **Shelving**

- (2) Two plastic coated wire shelves,
- Set of Stainless Steel shelf brackets,
- Easy remove for cleaning,
- Dimensions WxD: 21"x17" (533x432 mm),
22-1/4"x17" (565x432 mm).

➤ **Refrigeration**

- Temperature regulated by thermostatic control,
- Evaporative pan,
- Evaporator coil coated with anti-corrosion material 100% Polyester,
- Forced air refrigeration system,
- Refrigeration capacity: 1583 Btu/h (14°F) / 467 W (-10°C).

➤ **Electrical**

- Cord and NEMA 5-15P plug,
- Electrical connection is 115V / 1ph / 60 Hz.



OPTIONAL FEATURES

- ✓ Set of 2" diameter casters, with lock provided on front set,
- ✓ Electrical connection is: 220-230 V / 1ph / 50 Hz (plug type varies),
- ✓ Drawer kit,
- ✓ Flat lid,
- ✓ Single Overshelf,
- ✓ Double Overshelf.

➤ **ETL Listed to UL471 Standard and Sanitation classified to NSF7.**

PLAN VIEW

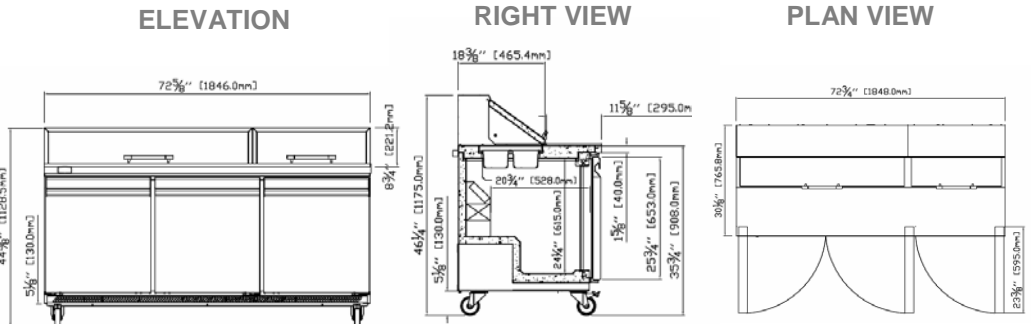

ETL LISTED TO UL471 STANDARD AND SANITATION CLASSIFIED TO NSF7 – WE RESERVE THE RIGHT TO CHANGE SPECIFICATIONS WITHOUT PRIOR NOTICE



Infrico USA Corp.
7042 N.W. 46th Street
Miami, FL 33166
1.305.777.9599 Office
1.305.777.9598 Fax

www.infrico.us
service@infrico.com
sales@infrico.com

APPROVALS: AVAILABLE AT:



Revision: 05 Date: 01/28/2015 UC72P_FT_62_5