

PROJECT NAME: \_\_\_\_\_ LOCATION: \_\_\_\_\_

ITEM: \_\_\_\_\_ MODEL: \_\_\_\_\_

## Undercounter Freezers



## FEATURES LIST

### CUF-28-X, CUF-36-X, CUF-48-X, CUF-60-X,

- Stainless steel exterior, aluminum interior and back.
- Refrigeration system keeps food at safe temperatures between -8°F and 0°F
- Self-Closing doors with 90 degree stay-open feature.
- Shelves: Adjustable heavy-duty PVC coated shelves
- Electronic control system makes it easy to adjust temperature set point and defrost frequency.
- Pre-installed 4" swivel casters with brakes.
- Easy to access condenser coil for cleaning and service.
- Uses R290 refrigerant, which is eco-friendly and more efficient.
- **WARRANTY:** 2 Years Parts and Labor and an additional 3 years on compressor

\* Not suitable for installation in a non-commercial or residential application

### Approvals



As continued product improvement is a policy, specifications are subject to change without notice

CONFORMS TO NSF/ANSI STD 7

## PLAN VIEW

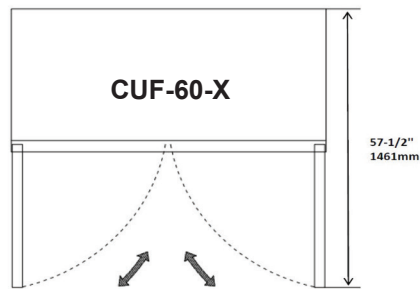
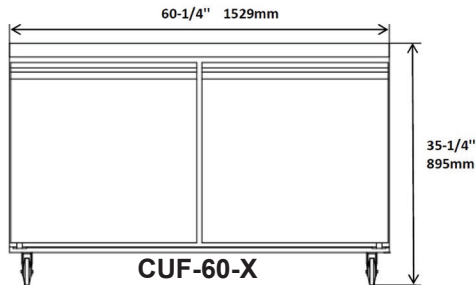
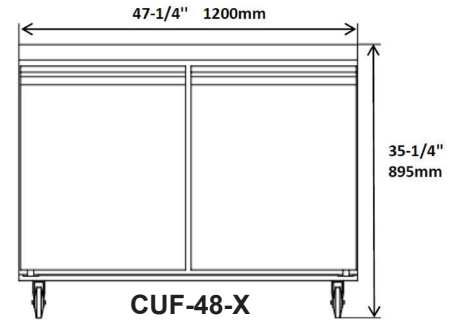
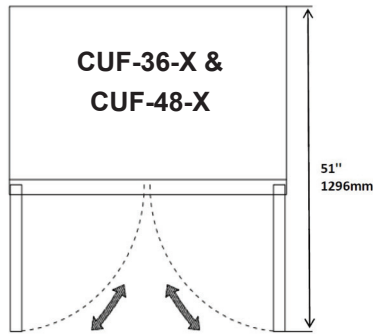
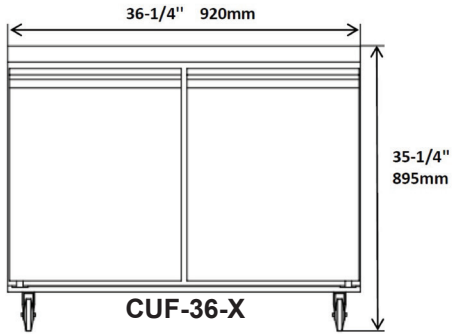
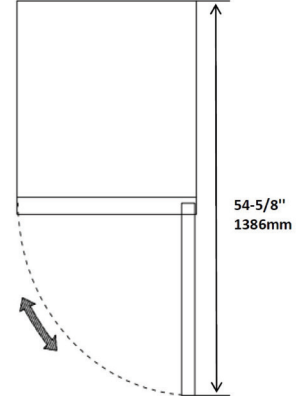
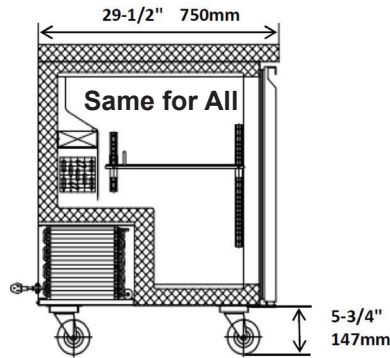
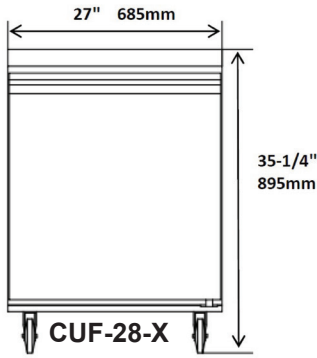

Model	Doors	Shelves	Cabinet Dim (in)			HP	Voltage /Hz /ph	Amp	NEMA Plug	Cord Lgth (ft)	Ship Weight (lbs)
			L	D	H						
CUF-28-X	1	1	27	29.5	35.25	1/5	115/60/1	2.1	5-15P	10	233
CUF-36-X	2	2	36.25	29.5	35.25	1/5	115/60/1	4.5	5-15P	10	245
CUF-48-X	2	2	47.25	29.5	35.25	1/4	115/60/1	3.1	5-15P	10	312
CUF-60-X	2	2	60.2	29.5	35.25	1/2	115/60/1	5.0	5-15P	10	323