

These bottle coolers will keep all of your beverages cold and ready to serve. Perfect for any size bar, pub, or restaurant that operates in a high-volume setting. These bottle coolers have a painted aluminum interior for easy cleaning and a black-coated steel exterior for a sleek look that goes well with any bar setting. Stainless steel sliding lids on the top allow for easy and quick access to the beverages inside the unit. Plastic-coated steel dividers help you keep your beverages organized, while the built-in bottle opener and cap catcher will keep your work area clean and free of debris. The lids are lockable so that the beverages inside the unit stay safe after hours. These models are ETL and ETL Sanitation listed. They are backed with a 1-year warranty on parts and labor; and a 5-year warranty on the compressor.

Bottle Coolers

- Black-coated steel exterior
- Painted aluminum interior liner
- Foamed-in-place polyurethane high density cell insulation throughout the entire cabinet
- Lockable stainless steel sliding lids
- Built-in bottle opener with cap catcher
- Automatic defrosting
- Plastic-coated dividers included
- 1-year warranty on parts and labor
- 5-year warranty on the compressor



VRBC50



VRBC65



Specifications

Model	Lids	Dividers	Net Volume (Cubic Ft)	Overall Dimensions WxDxH (inches)			HP	Voltage	Amps	Gross Weight
VRBC50	2	3	13	50"	28"	34"	1/3	115V	8	225 lbs
VRBC65	2	4	18	65"	28"	34"	1/3	115V	8.5	298 lbs

Plan Views

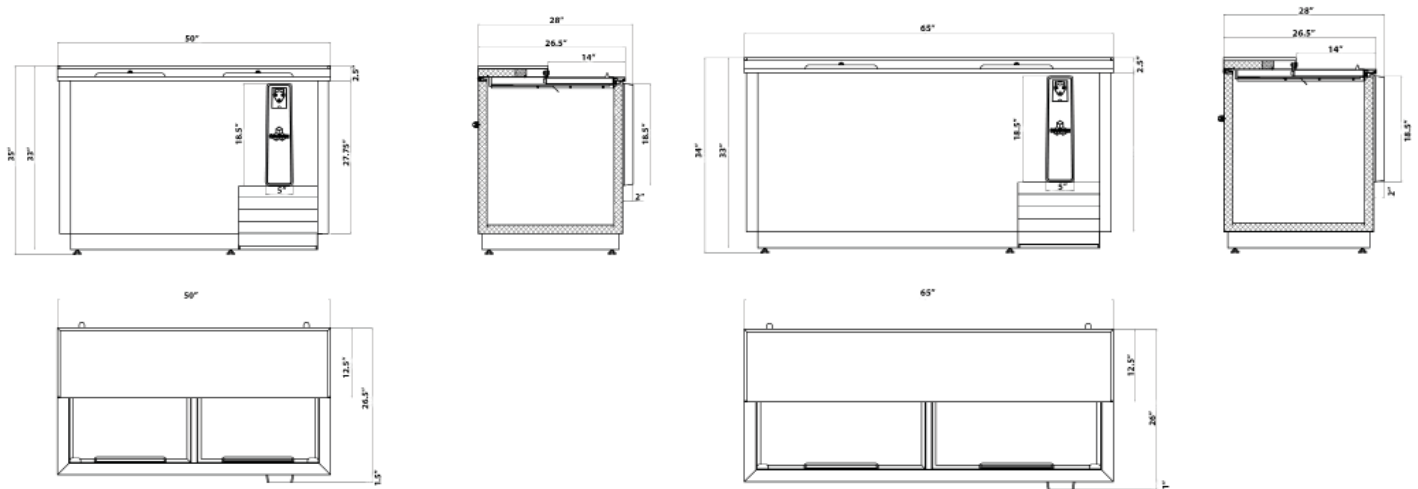

VRBC50

VRBC65

Features

Refrigeration System

- Use environmentally friendly R134A refrigerant
- Maintains a temperature range of 32°-41°F
- Rugged-built axial evaporator fans run efficiently, with low-velocity and high-volume air flow

Cabinet Construction

- Black-coated steel exterior for a sleek appearance
- Painted aluminum interior liner allows for easy cleaning
- The cabinet is insulated throughout with a foamed-in-place, high-density cell polyurethane insulation

Dividers

- Includes 3 plastic-coated steel dividers to keep contents organized and easy to get to during service
- Dividers are removable for easy cleaning

Electrical Control

- Mechanical temperature controller
- Temperature controller initiates automatic defrost schedule for worry free use
- 7-foot power cord with NEMA 5-15 plug



Lids

- Stainless steel sliding lids open and close smoothly, and provide easy access to the beverages inside the unit
- Lids are individually locking to keep the contents safe after hours
- Lids are insulated to keep beverages cold when they are closed

Model Features

- Built in bottle opener with cap catcher for fast bottle opening keeps the work area clean and free of debris on the floor