

These beer dispensers are an easy way to offer up cold and refreshing draft beers to your patrons. They feature a stainless steel tap tower that allows you to fill pint glasses and pitchers straight from the keg. Available in a wide range of sizes that can hold a number of different sized keg barrels both for use and storage. Adjustable shelves are also included for optional bottle or can storage. These units have solid black vinyl locking doors that conceal the contents inside and keep them secure after hours. The thick stainless steel top and built-in drip trays allow for easy clean-up. These models are ETL Listed and NSF approved and backed by a 1 year warranty on parts and labor and a 5 year warranty on the compressor.

28" Standard Depth Kegeators/Beer Dispensers

- Heavy duty, wear resistant laminated black vinyl front and sides
- All stainless steel countertop, tap towers and drip trays
- Interior is all stainless steel floor and inner walls
- 3" diameter stainless steel insulated beer columns
- R134a refrigerant ensures ideal operating temperatures
- Side mounted compressor optimizes interior space
- Foamed-in-place polyurethane high density cell insulation throughout the entire cabinet
- Includes plastic coated wire shelves for additional storage
- 1 year warranty on parts and labor
- 5 year warranty on the compressor



Specifications

Model	Doors/Taps	Shelves	Product Capacity	Net Volume (Cubic Ft)	Compressor HP	Overall Dimensions WxDxH (inches)	Voltage	Watts	Amps	Gross Weight
VUBD1	1 Door 1 Tap	N/A	Kegs: 1 Half Barrel 12 oz Cans: 30 6-pks 12 oz Bottles: 42 6-pks	6.5 Cu. Ft	1/6	23.5" x 30" x 38.75"	115V/60Hz	178W	1.7	176 lbs

Plan Views

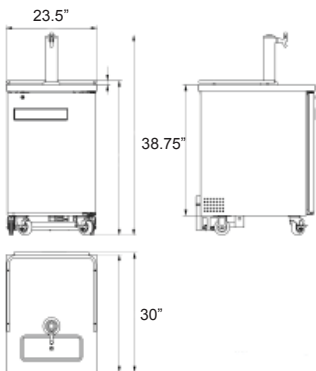

Features

Cooling System

- Refrigeration units use environmentally friendly R134A refrigerant
- Balanced refrigeration system helps to maintain a temperature range of 33°- 38°F
- Condensing unit is located behind front grill and slides out for easy cleaning

Electrical Control

- 115V/60 connection for all models
- 7' power cord with NEMA 5-15 plug from the back of the unit



Doors

- Laminated black vinyl exterior with heavy gauge steel liner
- 12" long recessed handles
- Postive seal doors
- Door locks come standard on all models

Cabinet Construction

- Exterior is constructed of a durable black vinyl front and sides with an aluminum back. Countertop is all stainless steel.
- Interior is constructed of all stainless steel floor and walls
- 3" diameter stainless steel insulated beer columns that has cold air directed into them to reduce foaming
- The cabinet is insulated throughout with a foamed-in-place high density cell polyurethane insulation

Shelving

- Heavy duty PVC coated wire shelves are adjustable
- Aluminum shelf support system that are adjustable for every 1/2"

Model Features

- Interior LED lighting for greater visibility throughout the cabinet
- NSF-7 Approved for the storage of packaged or bottled products

