

PROJECT NAME: \_\_\_\_\_ LOCATION: \_\_\_\_\_

ITEM: \_\_\_\_\_ MODEL: \_\_\_\_\_

## Commercial Gas Range

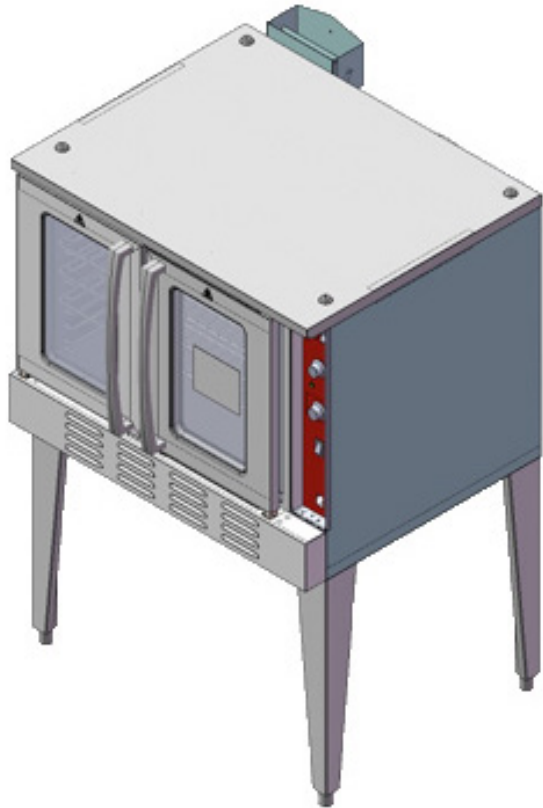

The Centaur Full Size Gas Convection Oven is ideal for any high volume restaurant or food service establishment. Constructed of stainless steel, this oven operates with a forced air, two speed fan motor system with a cool down feature. The interior of the oven has a 10 position rack guide and fits full size sheet pans. Electronic controls featuring a 60 minute timer and manual temperature knob. The double pane glass doors have a interlock switch that automatically turns the fan and burners off when they are opened. Includes steel legs with a powder black finish and adjustable bullet feet.

## FEATURES LIST

### C-CO-1-N, C-CO-1-P

All ranges are shipped as Natural Gas and have a conversion kit included with the range to convert it to propane

#### Construction

- All stainless steel construction
- Double pane thermal glass windows on doors
- Steel legs with a powder black finish and adjustable bullet feet
- Doors have an interlock switch that automatically turns the fan and burners off when open
- 3/4" rear NPT gas connection

#### Oven Features

- Oven interior measures 28.25" x 21.5" x 20"
- 1/4 HP two speed fan motor
- Cooking chamber is lined with porcelain enamel
- 10 position guide rack with 1.5" spacing in between
- Includes 5 heavy duty adjustable chrome plated racks
- Seamless interior and corners for easy cleaning

#### Controls

- 120V, 60hz controls for oven
- Temperature range from 150°F - 550°F
- 60 minute continuous ring timer with manual shut off
- Temperature ready indicator light
- 6' power cord with NEMA 5-15 Plug

#### Legs

- 32" long steel legs with a durable powder black coating
- Adjustable bullet feet
- Optional casters sold separately



Specifications subject to change without notice

## PLAN VIEW

- A pressure regulator is provided with this unit.  
Natural Gas 4.0" W.C.  
Propane Gas 10.0" W.C.
- Rear Gas Connection 3/4" NPT

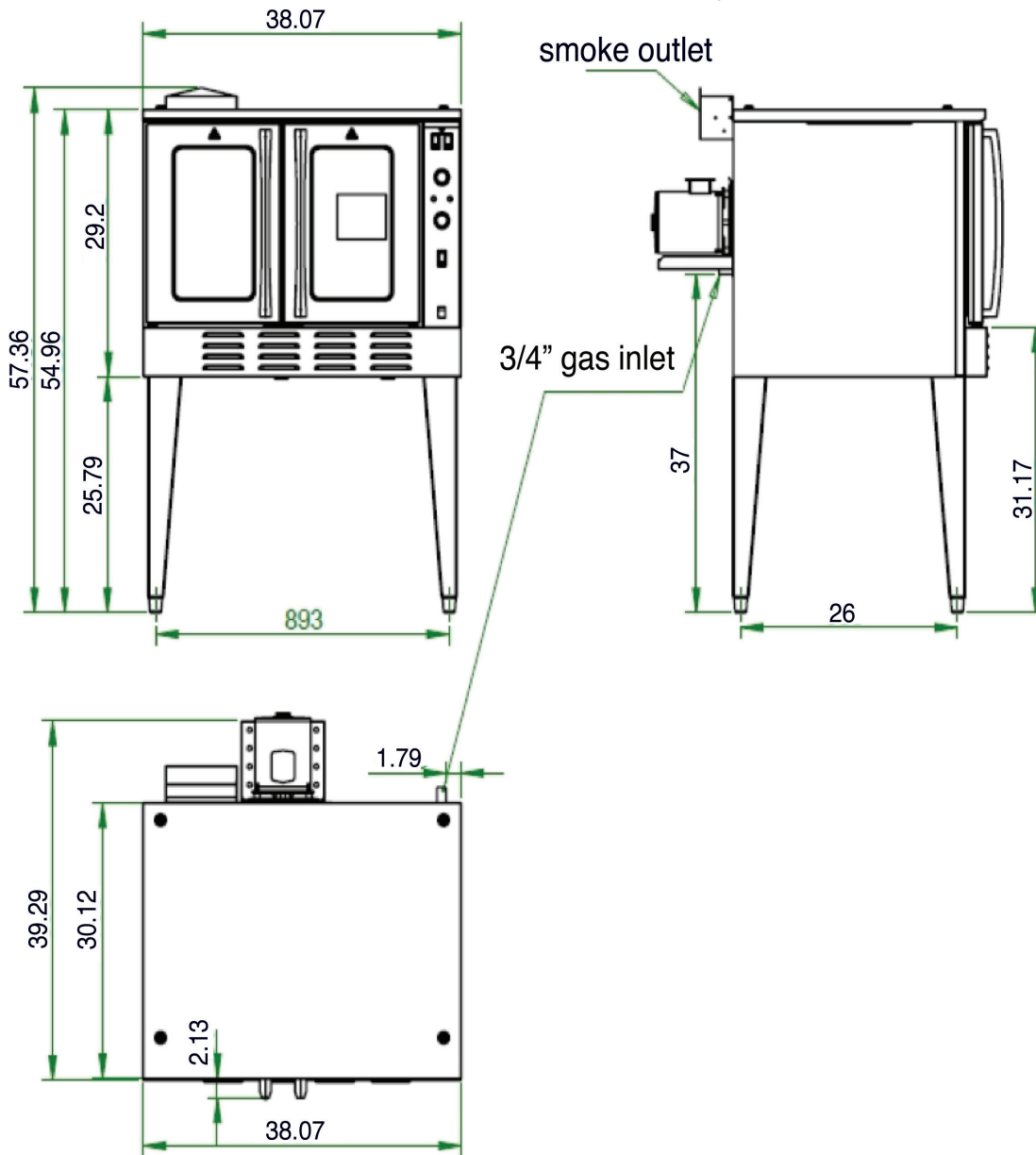

Model	Racks	External Dimensions			Internal Oven Dimensions			Total BTU's	Volts	Crated Weight (lbs)
		W	D	H	W	D	H			
C-CO-1-N	5	41	39	60	28.5	21.5	20	54,000	120V	579
C-CO-1-P	5	41	39	60	28.5	21.5	20	54,000	120V	579