

PROJECT NAME: _____ LOCATION: _____

ITEM: _____ MODEL: _____

Commercial Countertop Gas Range



With 25,000 BTU high heat per burner, this countertop gas range is a commercial range without an oven. The burners give you the maximum in gas range features, removable burners with the top half of the burner that separates for cleaning and a pilot that lights each burner. Heavy duty cast iron grates are also removable for easy cleaning.

A large control knob for each burner gives you a comfortable feel when turning burners on and off all day. Units are shipped for natural gas but are easily converted to LP (propane) gas with the LP conversion kit that is included.

All Countertop Gas Ranges carry ETL gas and sanitation approvals that meet US gas and sanitation requirements for use in restaurants.

FEATURES LIST

HP-12

- High Performance 25,000 BTU per individual burner
- Heavy cast iron burners with easy to clean lift off top
- Heavy cast iron removable burner grates
- Each burner has it's own adjustable pilot
- Large individual burner knobs with set screw
- Extended cool to touch front edge
- Removable, easy to clean full width stainless grease catch pan
- All grates are removable for easy cleaning
- Adjustable non-skid Stainless Steel legs
- 1 year parts and labor



Specifications subject to change without notice

PLAN VIEW

- A pressure regulator is provided with this unit.
Natural Gas 4.0" W.C.
Propane Gas 10.0" W.C.
- Gas connection is 3/4" NPT (19mm) rear gas connection.
- All equipment is supplied for Natural Gas, an LP conversion kit is also provided.

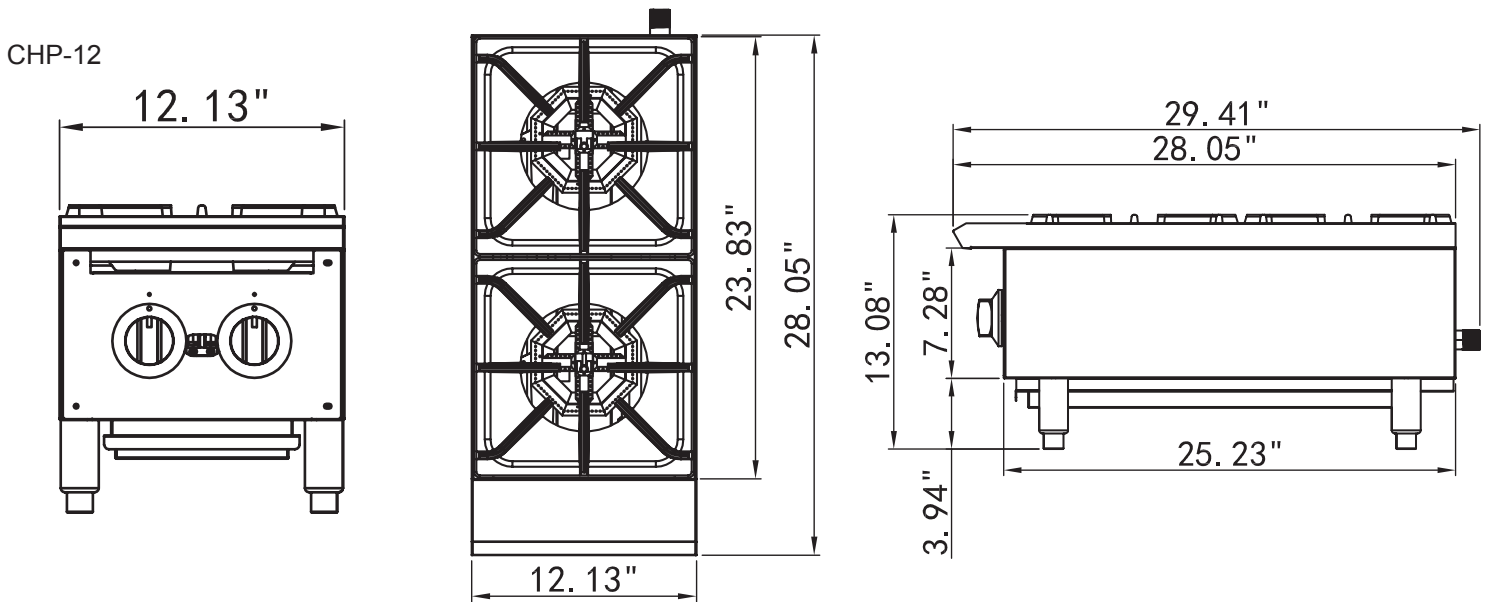

Model	Burners	Dimensions			BTU's (per burner)	Total BTU's	Crated Weight (lbs)
		W	D	H			
CHP-12	2	12.13	29.41	13.08	25,000	50,000	86